



PIONEERS
For Mining Trading F.Z.C

ROCK DRILLING TOOLS



Contents

	Page
History	3
Technical information Button bits	4
Warranty	5
Plug hole drills	6-7
Integral Drill Steel	8-10
Grinding of Integral drill steel	11
Tapered rods and bits 4° 46	12
Tapered rods and bits 7°	13
Tapered rods and bits 11°	14
Tapered rods and bits 12°	15-16
Tapered rods and bits HEX25 7°	17
Shank rods R23 and R25	18
Shank rods R28 and R32	19
Tunnelling and Drifting rods and bits	20-28
-R32/R25 rods	20
-R32/R28 rods	20
-Bits R25	21
-Bits R28	22
-R38/R32 rods	23-24
-T38/R32 rods	23-24
-Bits R32	25-26
-R38/R35 rods	27
-T38/R35 rods	27
-Bits R35	28
Extension Drilling rods and bits	29-45
-R25 rods	29
-Bits R25	30
-Bits R28	31
-R32 rods	32
-Bits R32	33-34
-T38 rods	35
-Bits T38	36-37
-T45 rods	38
-Bits T45	39-40
-T51 rods	41
-Bits T51	42-43
-T60 & MT60 rods	44
-Bits MT60	45
Shank adaptors	46-53

Technical information button bits

we produce a wide range of button bits; here are a few pointers to help you choose the right product.

The button bits have either parabolic (P) or hemispherical (H) inserts.



P

H

Button bits have dropcenter(D) or they are flat faced(F), some have flushing holes (front and/or gauge) and some have retrack function.

Our part numbers explained:

Tapered button bits: 11D38-7 P

Threaded button bits: 32R48RD H

11D = 11 Degrees

32R = R32 threads

38 /48= mm diameter

7 = 7 inserts

P/H = Parabolic or hemispherical inserts

R = Retrac

D = Dropcenter

N = Normal body

F = Flat faced



Retrac



Normal



D

Plug hole rods

SHANK 19mm x 108mm

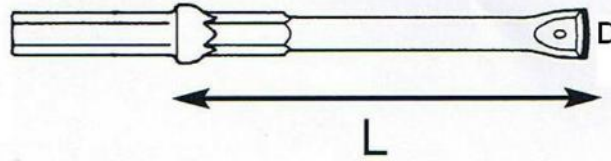

Length	Diameter	Weight	Part number
200mm	17mm	0,8kg	0721 2017-20
250mm	17mm	0,9kg	0721 2517-20
300mm	17mm	1,0kg	0721 3017-20
200mm	20mm	0,8kg	0721 2020-20
250mm	20mm	0,9kg	0721 2520-20
300mm	20mm	1,0kg	0721 3020-20
200mm	22mm	0,8kg	0721 2022-20
250mm	22mm	0,9kg	0721 2522-20
300mm	22mm	1,0kg	0721 3022-20
250mm	22mm	1,0kg	0721 2523-20
	23mm	0,9kg	

SHANK 19mm x 82,5mm

Length	Diameter	Weight	Part number
200mm	17mm	0,8kg	0722 2017-20
250mm	17mm	0,9kg	0722 2517-20
300mm	17mm	1,0kg	0722 3017-20
200mm	20mm	0,8kg	0722 2020-20
250mm	20mm	0,9kg	0722 2520-20
300mm	20mm	1,0kg	0722 3020-20
200mm	22mm	0,8kg	0722 2022-20
250mm	22mm	0,9kg	0722 2522-20
300mm	22mm	1,0kg	0722 3022-20
250mm	23mm	0,9kg	0722 2523-20

Plug hole rods

SHANK 22mm x 108mm

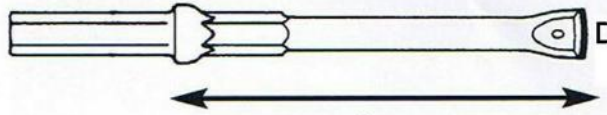

Length	Diameter	Weight	Part number
200mm	17mm	0,8kg	0711 2017-20
250mm	17mm	0,9kg	0711 2517-20
300mm	17mm	1,0kg	0711 3017-20
400mm	17mm	1,2kg	0711 4017-20
200mm	20mm	0,8kg	0711 2020-20
250mm	20mm	0,9kg	0711 2520-20
300mm	20mm	1,0kg	0711 3020-20
400mm	20mm	1,2kg	0711 4020-20
200mm	22mm	0,8kg	0711 2022-20
250mm	22mm	0,9kg	0711 2522-20
300mm	22mm	1,0kg	0711 3022-20
400mm	22mm	1,2kg	0711 4022-20

SHANK 22mm x 82.5mm

Length	Diameter	Weight	Part number
200mm	17mm	0,8kg	0712 2017-20
250mm	17mm	0,9kg	0712 2517-20
300mm	17mm	1,0kg	0712 3017-20
400mm	17mm	1,2kg	0712 4017-20
200mm	20mm	0,8kg	0712 2020-20
250mm	20mm	0,9kg	0712 2520-20
300mm	20mm	1,0kg	0712 3020-20
400mm	20mm	1,2kg	0712 4020-20
200mm	22mm	0,8kg	0712 2022-20
250mm	22mm	0,9kg	0712 2522-20
300mm	22mm	1,0kg	0712 3022-20
400mm	22mm	1,2kg	0712 4022-20

Integral Drill Steel

SHANK 19mm x 108mm



Series	Length	Diameter	Weight	Part number
21	400mm	29mm	1,65kg	0724 0429-20
21	800mm	28mm	2,85kg	0724 0828-20
21	1200mm	27mm	3,65kg	0724 1227-20
21	1600mm	27mm	4,05kg	0724 1627-20
22	2400mm	26mm	5,85kg	0724 2426-20
22	3200mm	25mm	7,65kg	0724 3225-20
22	4000mm	24mm	9,45kg	0724 4024-20

SHANK 22mm x 108mm

HEX 19mm body

Length	Diameter	Weight	Part number
400mm	29mm	1,65kg	0728 0429-20
800mm	28mm	2,85kg	0728 0828-20
1200mm	27mm	3,15kg	0728 1227-20
1600mm	27mm	4,05kg	0728 1627-20
2400mm	26mm	5,85kg	0728 2426-20
3200mm	25mm	7,65kg	0728 3225-20
4000mm	24mm	9,45kg	0728 4024-20
400mm	26mm	1,35kg	0728 0426-20
800mm	25mm	2,25kg	0728 0825-20
1200mm	24mm	3,15kg	0728 1224-20

Integral Drill Steel

Hex 22



Series	Length	Diameter	Weight	Part number
11	800mm	34mm	3,0kg	0714 0834-11
11	1600mm	33mm	5,4kg	0714 1633-11
11	2400mm	32mm	7,8kg	0714 2432-11
11	3200mm	31mm	10,2kg	0714 3231-11
11	4000mm	30mm	12,6kg	0714 4030-11
11	4800mm	29mm	15,0kg	0714 4829-11
11	5600mm	28mm	17,4kg	0714 5628-11
11	6400mm	27mm	19,8kg	0714 6427-11
11	7200mm	26mm	22,2kg	0714 7226-11
12	800mm	40mm	3,0kg	0714 0840-11
12	1600mm	39mm	5,4kg	0714 1639-11
12	2400mm	38mm	7,8kg	0714 2438-11
12	3200mm	37mm	10,2kg	0714 3237-11
12	4000mm	36mm	12,6kg	0714 4036-11
12	4800mm	35mm	15,0kg	0714 4835-11
12	5600mm	34mm	17,4kg	0714 5634-11
12	6400mm	33mm	19,8kg	0714 6433-11
12	7200mm	32mm	22,2kg	0714 7232-11
12	8000mm	31mm	24,6kg	0714 8031-11
12	8800mm	30mm	27,0kg	0714 8830-11
12	9600mm	29mm	29,4kg	0714 9629-11
Series	Length	Diameter	Weight	Part number
13	400mm	34mm	1,8kg	0714 0434-11
13	800mm	33mm	3,0kg	0714 0833-11
13	1200mm	32mm	4,2kg	0714 1232-11
13	1600mm	31mm	5,4kg	0714 1631-11
13	2000mm	30mm	6,6kg	0714 2030-11
16	600mm	35mm	2,4kg	0714 0635-11
16	1200mm	34mm	4,2kg	0714 1234-11
16	1800mm	33mm	6,0kg	0714 1833-11
16	2400mm	32mm	7,8kg	0714 2432-11
17	600mm	41mm	2,4kg	0714 0641-11
17	1200mm	40mm	4,2kg	0714 1240-11
17	1800mm	39mm	6,0kg	0714 1839-11
17	2400mm	38mm	7,8kg	0714 2438-11

3-wing and threaded integral drill steel

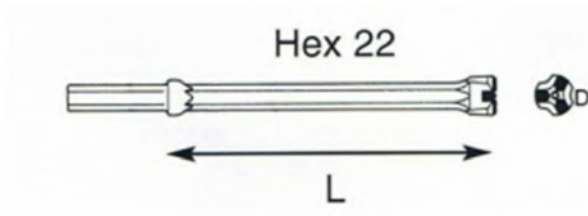

Length	Diameter	Weight	Part number
2400mm	38mm	7,8kg	0761 2438-10
3200mm	38mm	10,2kg	0761 3238-10
4000mm	38mm	12,6kg	0761 4038-10
4800mm	35mm	15,0kg	0761 4035-10

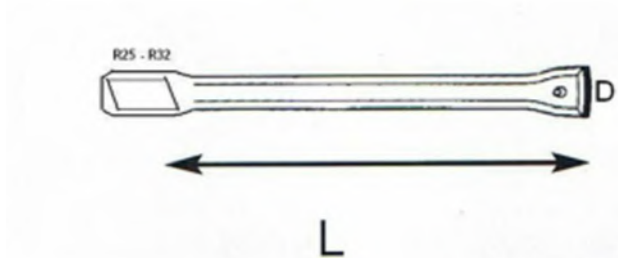

Length mm	Length ft	Diameter	Thread	Hex	Part number
1950mm	6,39ft	23 - 34mm	R28	H19	H19R28 1950 23
1950mm	6,39ft	27 - 45mm	R28	H22	H22R28 1950 34
1950mm	6,39ft	27 - 45mm	R32	H22	H22R32 1950 34

Grinding

Use Monark's grinding gauge when grinding chisel rods. The grinding gauge can be used for all rods made of H19, H22 and H25 and can be obtained by contacting your Monark representative.

Use the correct grinding wheel. Silicon carbide wheels with a ceramic binding agent must be used when grinding chisel rods.

Make sure that the grinding wheel is constantly in motion and apply the correct grinding pressure so that overheating of the hard metal is avoided.

Make sure there is adequate water-cooling while grinding. Use a special grinding wheel when dry grinding if water is not available. Avoid rapid cooling of the cutting edge.

GRIND AT THE RIGHT TIME

Check wear using the Monark grinding gauge. The rod should be ground when you observe the following:

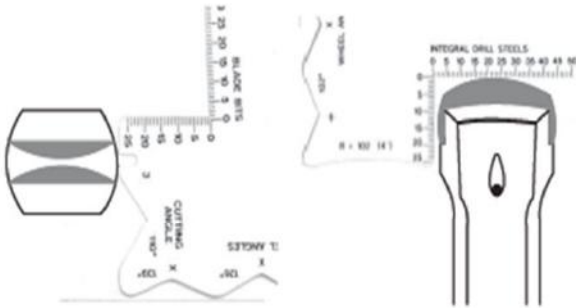

Extensive wear

When the wear flat, measured at a distance of 5mm from the cutter's periphery, is 3mm wide.

Diametric wear

When the anti taper height is 8 mm measured from the point where the taper begins.

THE EDGE SHOULD BE STRAIGHT AND IN THE MIDDLE OF THE INSERT

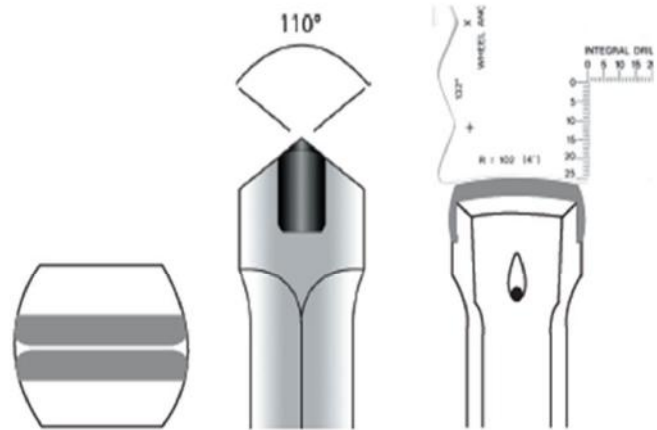

Grind an equal amount on both sides of the insert.

The insert should have a cutting angle of 110° and the insert radius should be 102 mm (4").

AVOID SHARPENING THE ENTIRE LENGTH OF THE INSERT

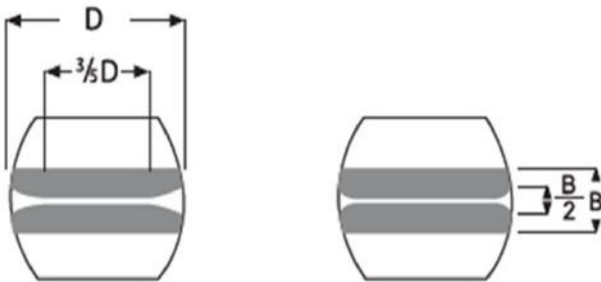

The middle 3/5 of the old wear edge is ground so that it is sharp. 1/5 of the old wear edge is retained at each of the corners.

Some types of rock cause heavy wear at the corners. Grind the insert so that the size of the corner chamfer corresponds to half the cutter width.

THE INSERT MUST BE PROPERLY GROUND

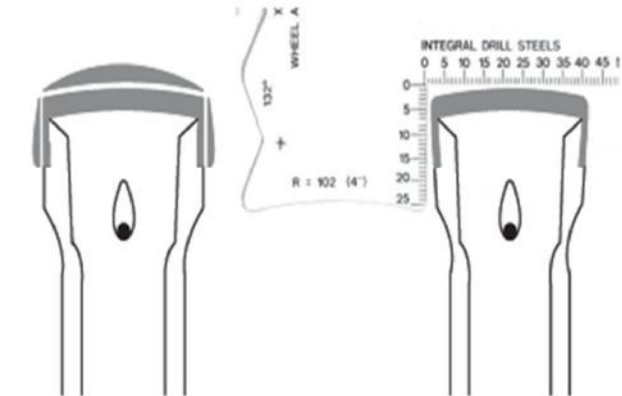

Reduce any anti taper through combined height and diameter grinding or by grinding only the height.

Grind the drill until the anti taper is a maximum of 6 mm.

NON-ABRASIVE CONDITIONS

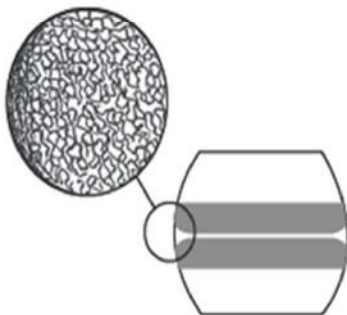

When used in very non-abrasive rock types, chisel rods can drill many holes and show little signs of wear. The rod must however be ground as soon as the surface roughness ("orange peel skin") or fatigue cracks are visible in the hard metal or solder joint. Even though this may not be visible the rod should still be lightly ground and honed after having drilled approximately 150 m.

AFTER GRINDING

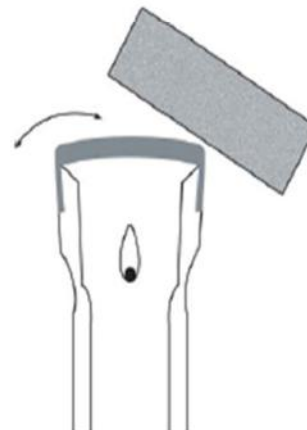

Clean up all sharp corners and edges.

Tapered rods 22x108mm and bits 4° 46

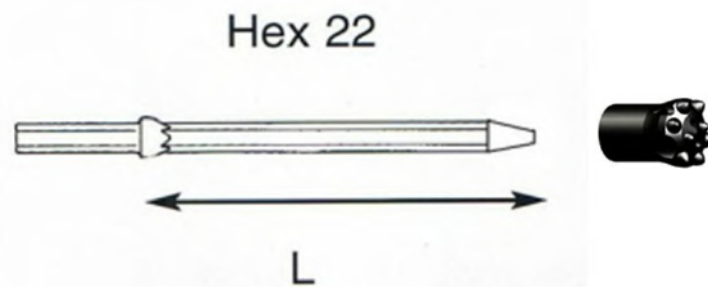

Length mm	Length ft	Degrees	Weight	Part number
400mm	1,31ft	4,46°	1,7kg	0714 0400-4,46°
610mm	2,00ft	4,46°	2,3kg	0714 0610-4,46°
800mm	2,62ft	4,46°	2,9kg	0714 0800-4,46°
1220mm	4,00ft	4,46°	4,1kg	0714 1220-4,46°
1600mm	5,24ft	4,46°	5,3kg	0714 1600-4,46°
1830mm	6,00ft	4,46°	5,9kg	0714 1830-4,46°
1980mm	6,49ft	4,46°	6,3kg	0714 1980-4,46°
2440mm	8,00ft	4,46°	7,7kg	0714 2440-4,46°
3050mm	10,00ft	4,46°	9,6kg	0714 3050-4,46°
3200mm	10,49ft	4,46°	10,1kg	0714 3200-4,46°
3660mm	12,00ft	4,46°	11,5kg	0714 3660-4,46°
4000mm	13,12ft	4,46°	12,5kg	0714 4000-4,46°
4800mm	15,74ft	4,46°	14,9kg	0714 4800-4,46°
5485mm	18,00ft	4,46°	17,4kg	0714 5485-4,46°
5600mm	18,37ft	4,46°	17,8kg	0714 5600-4,46°
6400mm	21,00ft	4,46°	19,7kg	0714 6400-4,46°
7200mm	23,62ft	4,46°	22,1kg	0714 7200-4,46°
7315mm	24,00ft	4,46°	22,4kg	0714 7315-4,46°



DIA MM	GAUGE CARBIDE	FACE CARBIDE	FACE FLUSHING	SIDE FLUSHING	PART
33	6 X 7MM	2 X 7MM	2 X 5MM	1 X 5MM	446D33-8
33	5 X 7MM	2 X 7MM	1 X 5MM	2 X 5MM	446D33-7
35	6 X 7MM	2 X 7MM	2 X 5MM	1 X 5MM	446D35-8
38	6 X 9MM	2 X 7MM	2 X 5MM	1 X 5MM	446D38-8
41	6 X 9MM	2 X 7MM	2 X 5MM	1 X 5MM	446D41-8
41	5 X 9MM	2 X 7MM	1 X 5MM	2 X 5MM	446D41-7

Tapered rods 22x108mm and bits 7°

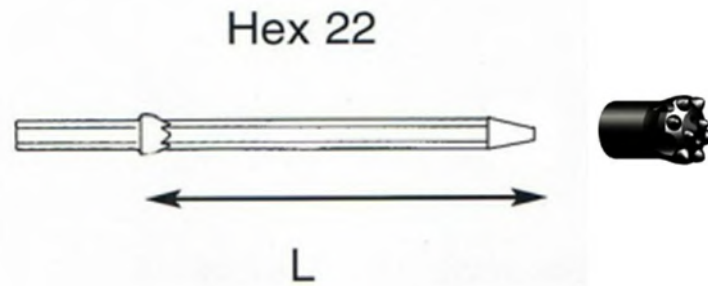

Length mm	Length ft	Degrees	Weight	Part number
400mm	1,31ft	7°	1,7kg	0714 0400-7°
610mm	2,00ft	7°	2,3kg	0714 0610-7°
800mm	2,62ft	7°	2,9kg	0714 0800-7°
1220mm	4,00ft	7°	4,1kg	0714 1220-7°
1600mm	5,24ft	7°	5,3kg	0714 1600-7°
1830mm	6,00ft	7°	5,9kg	0714 1830-7°
1980mm	6,49ft	7°	6,3kg	0714 1980-7°
2440mm	8,00ft	7°	7,7kg	0714 2440-7°
3050mm	10,00ft	7°	9,6kg	0714 3050-7°
3200mm	10,49ft	7°	10,1kg	0714 3200-7°
3660mm	12,00ft	7°	11,5kg	0714 3660-7°
4000mm	13,12ft	7°	12,5kg	0714 4000-7°
4800mm	15,74ft	7°	14,9kg	0714 4800-7°
5485mm	18,00ft	7°	17,4kg	0714 5485-7°
5600mm	18,37ft	7°	17,8kg	0714 5600-7°
6400mm	21,00ft	7°	19,7kg	0714 6400-7°
7200mm	23,62ft	7°	22,1kg	0714 7200-7°
7315mm	24,00ft	7°	22,4kg	0714 7315-7°



DIA MM	GAUGE CARBIDE	FACE CARBIDE	FACE FLUSHING	SIDE FLUSHING	PART
33	6 X 7MM	2 X 7MM	2 X 5MM	1 X 5MM	7D33-8
33	5 X 7MM	2 X 7MM	1 X 5MM	2 X 5MM	7D33-7
35	6 X 7MM	2 X 7MM	2 X 5MM	1 X 5MM	7D35-8
38	6 X 9MM	2 X 7MM	2 X 5MM	1 X 5MM	7D38-8
41	6 X 9MM	2 X 7MM	2 X 5MM	1 X 5MM	7D41-8
41	5 X 9MM	2 X 7MM	1 X 5MM	2 X 5MM	7D41-7

Tapered rods 22x108mm and bits 11°

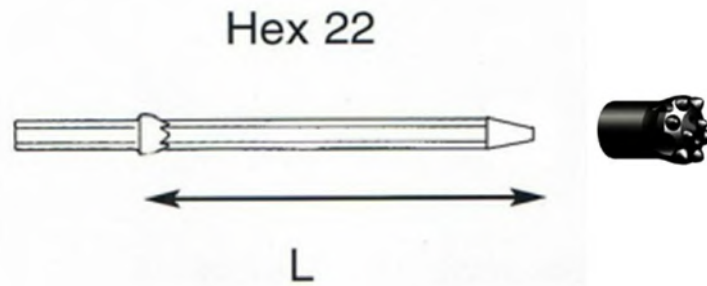

Length mm	Length ft	Degrees	Weight	Part number
400mm	1,31ft	11°	1,7kg	0714 0400-11°
610mm	2,00ft	11°	2,3kg	0714 0610-11°
800mm	2,62ft	11°	2,9kg	0714 0800-11°
915mm	3,00ft	11°	3.45kg	0714 0915-11°
1220mm	4,00ft	11°	4,1kg	0714 1220-11°
1600mm	5,24ft	11°	5,3kg	0714 1600-11°
1830mm	6,00ft	11°	5,9kg	0714 1830-11°
1980mm	6,49ft	11°	6,3kg	0714 1980-11°
2440mm	8,00ft	11°	7,7kg	0714 2440-11°
3050mm	10,00ft	11°	9,6kg	0714 3050-11°
3200mm	10,49ft	11°	10,1kg	0714 3200-11°
3660mm	12,00ft	11°	11,5kg	0714 3660-11°
4000mm	13,12ft	11°	12,5kg	0714 4000-11°
4800mm	15,74ft	11°	14,9kg	0714 4800-11°
5485mm	18,00ft	11°	17,4kg	0714 5485-11°
5600mm	18,37ft	11°	17,8kg	0714 5600-11°
6400mm	21,00ft	11°	19,7kg	0714 6400-11°
7200mm	23,62ft	11°	22,1kg	0714 7200-11°
7315mm	24,00ft	11°	22,4kg	0714 7315-11°



DIA MM	GAUGE CARBIDE	FACE CARBIDE	FACE FLUSHING	SIDE FLUSHING	PART
33	6 X 7MM	2 X 7MM	2 X 5MM	1 X 5MM	11D33-8
33	5 X 7MM	2 X 7MM	1 X 5MM	2 X 5MM	11D33-7
35	6 X 7MM	2 X 7MM	2 X 5MM	1 X 5MM	11D35-8
38	6 X 9MM	2 X 7MM	2 X 5MM	1 X 5MM	11D38-8
38	5 X 9MM	2 X 7MM	1 X 5MM	2 X 5MM	11D38-7
41	6 X 9MM	2 X 7MM	2 X 5MM	1 X 5MM	11D41-8
41	5 X 9MM	2 X 7MM	1 X 5MM	2 X 5MM	11D41-7

Tapered rods 22x108mm and bits 12°

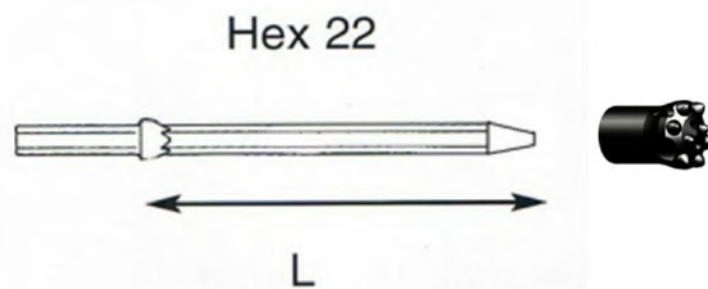

Length mm	Length ft	Degrees	Weight	Part number
400mm	1,31ft	12°	1,7kg	0714 0400-12°
610mm	2,00ft	12°	2,3kg	0714 0610-12°
800mm	2,62ft	12°	2,9kg	0714 0800-12°
915mm	3,00ft	12°	3.45kg	0714 0915-12°
1220mm	4,00ft	12°	4,1kg	0714 1220-12°
1600mm	5,24ft	12°	5,3kg	0714 1600-12°
1830mm	6,00ft	12°	5,9kg	0714 1830-12°
1980mm	6,49ft	12°	6,3kg	0714 1980-12°
2440mm	8,00ft	12°	7,7kg	0714 2440-12°
3050mm	10,00ft	12°	9,6kg	0714 3050-12°
3200mm	10,49ft	12°	10,1kg	0714 3200-12°
3660mm	12,00ft	12°	11,5kg	0714 3660-12°
4000mm	13,12ft	12°	12,5kg	0714 4000-12°
4800mm	15,74ft	12°	14,9kg	0714 4800-12°
5485mm	18,00ft	12°	17,4kg	0714 5485-12°
5600mm	18,37ft	12°	17,8kg	0714 5600-12°
6400mm	21,00ft	12°	19,7kg	0714 6400-12°
7200mm	23,62ft	12°	22,1kg	0714 7200-12°
7315mm	24,00ft	12°	22,4kg	0714 7315-12°

Tapered bits 12°



DIA MM	GAUGE CARBIDE	FACE CARBIDE	FACE FLUSHING	SIDE FLUSHING	PART
32	6 X 7MM	2 X 7MM	2 X 5MM	1 X 5MM	12D32-8
32	5 X 7MM	2 X 7MM	1 X 5MM	2 X 5MM	12D32-7
33	6 X 7MM	2 X 7MM	2 X 5MM	1 X 5MM	12D33-8
33	5 X 7MM	2 X 7MM	1 X 5MM	2 X 5MM	12D33-7
35	6 X 7MM	2 X 7MM	2 X 5MM	1 X 5MM	12D35-8
38	6 X 9MM	2 X 7MM	2 X 5MM	1 X 5MM	12D38-8
38	5 X 9MM	2 X 7MM	1 X 5MM	2 X 5MM	12D38-7
41	6 X 9MM	2 X 7MM	2 X 5MM	1 X 5MM	12D41-8
41	5 X 9MM	2 X 7MM	1 X 5MM	2 X 5MM	12D41-7
45	6 X 9MM	2 X 8MM	2 X 5MM	1 X 5MM	12D45-8
45	5 X 9MM	2 X 8MM	1 X 5MM	2 X 5MM	12D45-7

Tapered rods 25x108mm and bits 7°

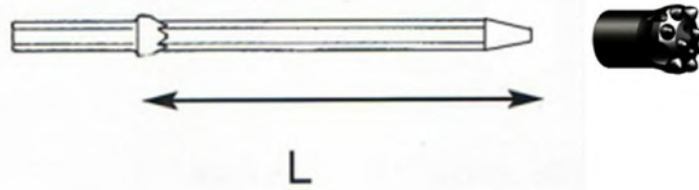

Length mm	Length ft	Degrees	Kg	Part number
1600mm	5,24ft	7°	6,8kg	0734 1600-7*
1800mm	5,90ft	7°	7,7kg	0734 1800-7*
2000mm	6,56ft	7°	8,5kg	0734 2000-7*
2200mm	7,21ft	7°	9,4kg	0734 2200-7*
2400mm	7,87ft	7°	10,3kg	0734 2400-7*
2500mm	8,20ft	7°	10,7kg	0734 2400-7*
3200mm	10,49ft	7°	13,7kg	0734 3200-7*

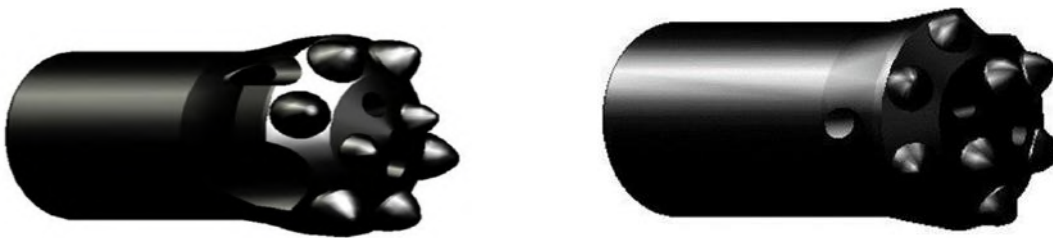

DIA MM	GAUGE CARBIDE	FACE CARBIDE	FACE FLUSHING	SIDE FLUSHING	PART
33	6 X 7MM	2 X 7MM	2 X 5MM	1 X 5MM	7D33-8
33	5 X 7MM	2 X 7MM	1 X 5MM	2 X 5MM	7D33-7
35	6 X 7MM	2 X 7MM	2 X 5MM	1 X 5MM	7D35-8
38	6 X 9MM	2 X 7MM	2 X 5MM	1 X 5MM	7D38-8
41	6 X 9MM	2 X 7MM	2 X 5MM	1 X 5MM	7D41-8
41	5 X 9MM	2 X 7MM	1 X 5MM	2 X 5MM	7D41-7

Shank rods R23 and R25

Hex 22

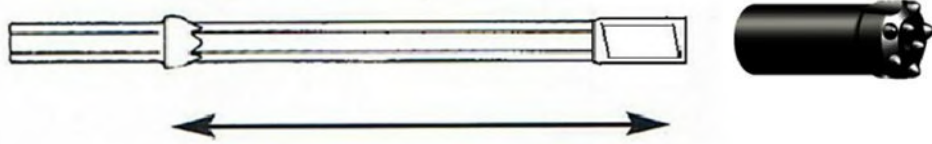

Length mm	Length ft	Thread	Weight	Part number
250mm	0,80ft	R23	1,4kg	0714 0250 R23
400mm	1,31ft	R23	1,8kg	0714 0400 R23
800mm	2,62ft	R23	3,0kg	0714 0800 R23
1600mm	5,24ft	R23	5,4kg	0714 1600 R23
1830mm	6,00ft	R23	6,3kg	0714 1830 R23
1980mm	6,49ft	R23	6,7kg	0714 1980 R23
2400mm	7,87ft	R23	7,8kg	0714 2400 R23
2440mm	8,00ft	R23	8,1kg	0714 2440 R23
3050mm	10,00ft	R23	9,9kg	0714 3050 R23
3200mm	10,49ft	R23	10,5kg	0714 3200 R23
3600mm	11,81ft	R23	11,6kg	0714 3600 R23
4000mm	13,12ft	R23	12,6kg	0714 4000 R23

Length mm	Length ft	Thread	Kg	Part number
250mm	0,80ft	R25	1,4kg	0714 0250 R25
400mm	1,31ft	R25	1,8kg	0714 0400 R25
800mm	2,62ft	R25	3,0kg	0714 0800 R25
1220mm	4,00ft	R25	4,2kg	0714 1220 R25
1600mm	5,24ft	R25	5,4kg	0714 1600 R25
1830mm	6,00ft	R25	6,3kg	0714 1830 R25
1980mm	6,49ft	R25	6,7kg	0714 1980 R25
2400mm	7,87ft	R25	7,8kg	0714 2400 R25
2440mm	8,00ft	R25	8,1kg	0714 2440 R25
3050mm	10,00ft	R25	9,9kg	0714 3050 R25
3200mm	10,49ft	R25	10,5kg	0714 3200 R25
3600mm	11,81ft	R25	11,6kg	0714 3600 R25
4000mm	13,12ft	R25	12,6kg	0714 4000 R25

Shank rods R28 and R32

Hex 22

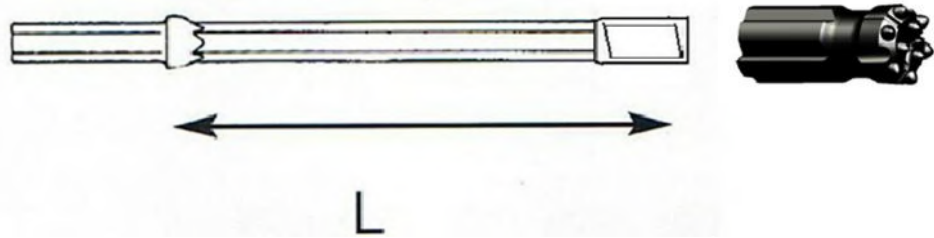

Length mm	Length ft	Thread	Kg	Part number
250mm	0,80ft	R28	1,4kg	0714 0250 R28
400mm	1,31ft	R28	1,8kg	0714 0400 R28
800mm	2,62ft	R28	3,0kg	0714 0800 R28
1600mm	5,24ft	R28	5,4kg	0714 1600 R28
1830mm	6,00ft	R28	6,3kg	0714 1830 R28
1980mm	6,49ft	R28	6,7kg	0714 1980 R28
2400mm	7,87ft	R28	7,8kg	0714 2400 R28
2440mm	8,00ft	R28	8,1kg	0714 2440 R28
3050mm	10,00ft	R28	9,9kg	0714 3050 R28
3200mm	10,49ft	R28	10,5kg	0714 3200 R28
3600mm	11,81ft	R28	11,6kg	0714 3600 R28
4000mm	13,12ft	R28	12,6kg	0714 4000 R28

Length mm	Length ft	Thread	Kg	Part number
250mm	0,80ft	R32	1,4kg	0714 0250 R32
400mm	1,31ft	R32	1,8kg	0714 0400 R32
800mm	2,62ft	R32	3,0kg	0714 0800 R32
1600mm	5,24ft	R32	5,4kg	0714 1600 R32
1830mm	6,00ft	R32	6,3kg	0714 1830 R32
1980mm	6,49ft	R32	6,7kg	0714 1980 R32
2400mm	7,87ft	R32	7,8kg	0714 2400 R32
2440mm	8,00ft	R32	8,1kg	0714 2440 R32
3050mm	10,00ft	R32	9,9kg	0714 3050 R32
3200mm	10,49ft	R32	10,5kg	0714 3200 R32
3600mm	11,81ft	R32	11,6kg	0714 3600 R32
4000mm	13,12ft	R32	12,6kg	0714 4000 R32

TUNNELLING AND DRIFTING

Rods R32/R25 HEX 25 BODY



EFF. LENGTH	PART
2020mm	DR3225-2020-H25
2480mm	DR3225-2480-H25
2900mm	DR3225-2900-H25
3090mm	DR3225-3090-H25
3700mm	DR3225-3700-H25
4300mm	DR3225-4300-H25
5525mm	DR3225-5525-H25

COUPLINGS

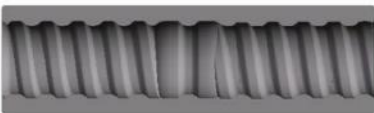

DIA (mm)	LENGTH	DESCR	PART
45	159	R32 SB CPL	CPLR32-45
55	175	R32 SB CPL	CPLR32-55

Rods R32/R28 HEX 28 BODY

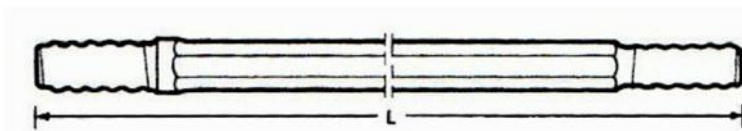

EFF. LENGTH	PART
2480mm	DR3228-2480-H28
2785mm	DR3228-2785-H28
3090mm	DR3228-3090-H28
3700mm	DR3228-3700-H28
4300mm	DR3228-4300-H28
5525mm	DR3228-5525-H28

TUNNELLING AND DRIFTING

BUTTON BITS R25

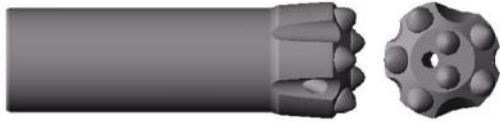

DIA .	GAUGE CARBIDE	FRONT CARBIDE	SIDE FLUSHING	FACE FLUSHING	GAUGE ANGLE	PART NUMBER
33	5 x 7mm	2 x 7mm	2 x 5mm	1 x 5mm	35	25R33NF
35	5 x 8mm	2 x 7mm	2 x 5mm	1 x 5mm	35	25R35NF
37	5 x 9mm	2 x 7mm	2 x 5mm	1 x 5mm	35	25R37NF
38	5 x 9mm	2 x 7mm	2 x 5mm	1 x 5mm	35	25R38NF
41	5 x 9mm	2 x 8mm	2 x 5mm	1 x 5mm	35	25R41NF
45	5 x 10mm	2 x 9mm	2 x 6mm	1 x 6mm	35	25R45NF
48	5 x 10mm	2 x 9mm	2 x 6mm	1 x 5mm	35	25R48NF



DIA .	GAUGE CARBIDE	FRONT CARBIDE	SIDE FLUSHING	FACE FLUSHING	GAUGE ANGLE	PART NUMBER
33	6 x 7mm	2 x 7mm	1 x 5mm	2 x 5mm	35	25R33NF8
35	6 x 7mm	2 x 7mm	1 x 5mm	2 x 5mm	35	25R35NF8
37	6 x 8mm	2 x 7mm	1 x 5mm	2 x 5mm	35	25R37NF8
38	6 x 8mm	2 x 7mm	1 x 5mm	2 x 5mm	35	25R38NF8
41	6 x 8mm	2 x 8mm	1 x 5mm	2 x 5mm	35	25R41NF8
45	6 x 9mm	2 x 8mm	1 x 6mm	2 x 6mm	35	25R45NF8
48	6 x 10mm	2 x 9mm	1 x 6mm	2 x 6mm	35	25R48NF8



DIA .	GAUGE CARBIDE	FRONT CARBIDE	SIDE FLUSHING	FACE FLUSHING	GAUGE ANGLE	PART NUMBER
38	6 x 8mm	3 x 7mm	1 x 5mm	3 x 5mm	35	25R38NG
45	6 x 9mm	3 x 7mm	1 x 5mm	3 x 5mm	35	25R45NG
48	6 x 10mm	3 x 9mm	1 x 6mm	3 x 5mm	35	25R48NG
51	6 x 10mm	3 x 9mm	1 x 6mm	3 x 5mm	35	25R51NG

TUNNELLING AND DRIFTING

BUTTON BITS R28

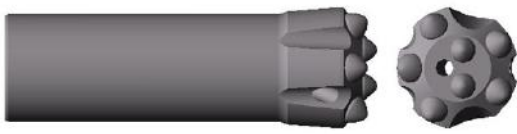

DIA .	GAUGE CARBIDE	FRONT CARBIDE	SIDE FLUSHING	FACE FLUSHING	GAUGE ANGLE	PART NUMBER
37	5 x 9mm	2 x 7mm	2 x 5mm	1 x 5mm	35	28R37NF
38	5 x 9mm	2 x 7mm	2 x 5mm	1 x 5mm	35	28R38NF
41	5 x 9mm	2 x 8mm	2 x 5mm	1 x 5mm	35	28R41NF
45	5 x 10mm	2 x 9mm	2 x 6mm	1 x 6mm	35	28R45NF
48	5 x 10mm	2 x 9mm	2 x 6mm	1 x 6mm	35	28R48NF



DIA .	GAUGE CARBIDE	FRONT CARBIDE	SIDE FLUSHING	FACE FLUSHING	GAUGE ANGLE	PART NUMBER
37	6 x 8mm	2 x 7mm	1 x 5mm	2 x 5mm	35	28R37NF8
38	6 x 8mm	2 x 7mm	1 x 5mm	2 x 5mm	35	28R38NF8
41	6 x 8mm	2 x 8mm	1 x 5mm	2 x 5mm	35	28R41NF8
45	6 x 9mm	2 x 8mm	1 x 6mm	2 x 6mm	35	28R45NF8
48	6 x 10mm	2 x 9mm	1 x 6mm	2 x 6mm	35	28R48NF8



DIA .	GAUGE CARBIDE	FRONT CARBIDE	SIDE FLUSHING	FACE FLUSHING	GAUGE ANGLE	PART NUMBER
38	6 x 8mm	3 x 7mm	1 x 5mm	3 x 5mm	35	28R38NG
45	6 x 9mm	3 x 8mm	1 x 5mm	3 x 5mm	35	28R45NG
48	6 x 10mm	3 x 9mm	1 x 6mm	3 x 5mm	35	28R48NG
51	6 x 10mm	3 x 9mm	1 x 6mm	3 x 5mm	35	28R51NG

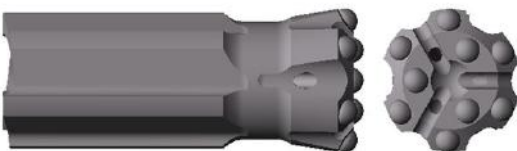

DIA .	GAUGE CARBIDE	FRONT CARBIDE	SIDE FLUSHING	FACE FLUSHING	GAUGE ANGLE	PART NUMBER
45	6 x 9mm	3 x 8mm	-	3 x 5mm	35	28R45RD

TUNNELLING AND DRIFTING

Rods R38/R32 HEX 32mm



EFF. LENGTH	PART
3090mm	DR3832-3090-H32
3700mm	DR3832-3700-H32
4300mm	DR3832-4300-H32
4915mm	DR3832-4915-H32
5525mm	DR3832-5525-H32

Rods T38/R32 HEX 32mm

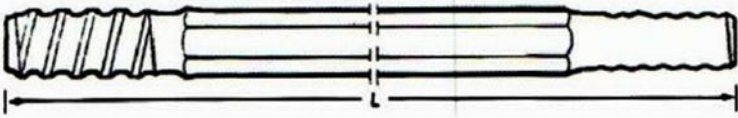

EFF. LENGTH	PART
3090mm	DRT3832-3090-H32
3700mm	DRT3832-3700-H32
4300mm	DRT3832-4300-H32
4915mm	DRT3832-4915-H32
5525mm	DRT3832-5525-H32

Rods R38/R32 HEX 35mm

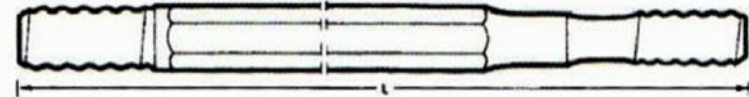

EFF. LENGTH	PART
3090mm	DR3832-3090-H35
3700mm	DR3832-3700-H35
4300mm	DR3832-4300-H35
4915mm	DR3832-4915-H35
5525mm	DR3832-5525-H35

Rods T38/R32 HEX 35mm

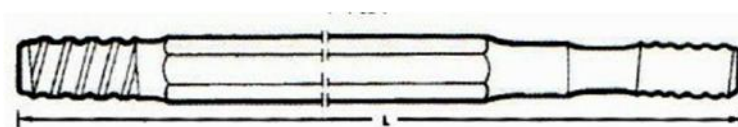

EFF. LENGTH	PART
3090mm	DRT3832-3090-H35
3700mm	DRT3832-3700-H35
4300mm	DRT3832-4300-H35
4915mm	DRT3832-4915-H35
5525mm	DRT3832-5525-H35

TUNNELLING AND DRIFTING

Rods T38F/R32M HEX 35mm

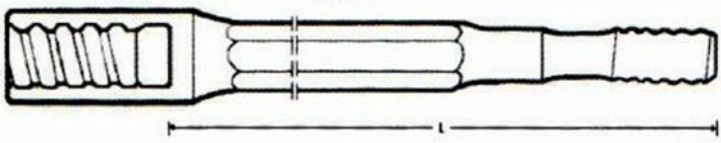

EFF. LENGTH	PART
3100mm	MF3832-3100-H35
3700mm	MF3832-3700-H35
4305mm	MF3832-4305-H35
4915mm	MF3832-4915-H35
5525mm	MF3832-5525-H35

Rods T38/R32 ROUND 39mm

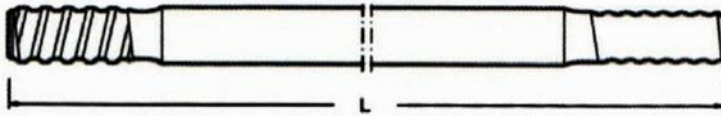

EFF. LENGTH	PART
3100mm	DRT3832-3100-39
3700mm	DRT3832-3700-39
4305mm	DRT3832-4305-39
4915mm	DRT3832-4915-39
5525mm	DRT3832-5525-39
6440mm	DRT3832-6440-39

Rods T38F/R32M ROUND 39mm

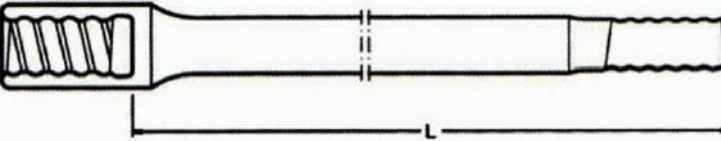

EFF. LENGTH	PART
3100mm	MF3832-3100-39
3700mm	MF3832-3700-39
4305mm	MF3832-4305-39
4915mm	MF3832-4915-39
5525mm	MF3832-5525-39
6440mm	MF3832-6440-39

COUPLINGS

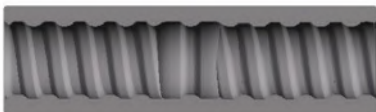

DIA (mm)	LENGTH	DESCR	PART
55	175	R38 SB CPL	CPLR38-55
55	190	R38 SB CPL	CPLT38-55

TUNNELLING AND DRIFTING

BUTTON BITS R32

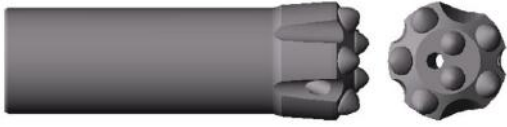

DIA .	GAUGE CARBIDE	FRONT CARBIDE	SIDE FLUSHING	FACE FLUSHING	GAUGE ANGLE	PART NUMBER
45	5 x 10mm	2 x 9mm	2 x 6mm	1 x 6mm	35	32R45NF
48	5 x 10mm	2 x 9mm	2 x 6mm	1 x 6mm	35	32R48NF
51	5 x 10mm	2 x 9mm	2 x 6mm	1 x 6mm	35	32R51NF



DIA .	GAUGE CARBIDE	FRONT CARBIDE	SIDE FLUSHING	FACE FLUSHING	GAUGE ANGLE	PART NUMBER
41	6 x 8mm	2 x 8mm	1 x 5mm	2 x 5mm	35	32R41NF8
43	6 x 9mm	2 x 8mm	1 x 5mm	2 x 5mm	35	32R43NF8



DIA .	GAUGE CARBIDE	FRONT CARBIDE	SIDE FLUSHING	FACE FLUSHING	GAUGE ANGLE	PART NUMBER
45	6 x 9mm	3 x 8mm	1 x 5mm	3 x 5mm	35	32R45NG



DIA .	GAUGE CARBIDE	FRONT CARBIDE	SIDE FLUSHING	FACE FLUSHING	GAUGE ANGLE	PART NUMBER
48	6 x 10mm	3 x 9mm	1 x 6mm	3 x 5mm	35	32R48ND
51	6 x 10mm	3 x 9mm	1 x 6mm	3 x 5mm	35	32R51ND
64	6 x 11mm	3 x 10mm	1 x 7mm	3 x 8mm	35	32R64ND



DIA .	GAUGE CARBIDE	FRONT CARBIDE	SIDE FLUSHING	FACE FLUSHING	GAUGE ANGLE	PART NUMBER
57	6 x 10mm	3 x 9mm	1 x 8mm	1 x 8mm	35	32R57NF

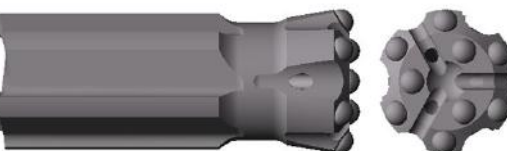

DIA .	GAUGE CARBIDE	FRONT CARBIDE	SIDE FLUSHING	FACE FLUSHING	GAUGE ANGLE	PART NUMBER
48	6 x 10mm	3 x 9mm	-	3 x 5mm	35	32R48RD
51	6 x 10mm	3 x 9mm	-	3 x 5mm	35	32R51RD
64	6 x 11mm	3 x 10mm	1 x 7mm	3 x 8mm	35	32R64RD

TUNNELLING AND DRIFTING

BUTTON BITS R32

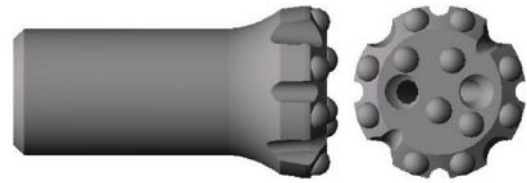

DIA	GAUGE CARBIDE	FRONT CARBIDE	SIDE FLUSHING	FACE FLUSHING	GAUGE ANGLE	PART NUMBER
64	8 x 10mm	4 x 10mm	1 x 7mm	2 x 9mm	35	32R64NF

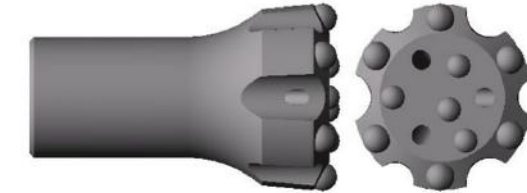

DIA	GAUGE CARBIDE	FRONT CARBIDE	SIDE FLUSHING	FACE FLUSHING	GAUGE ANGLE	PART NUMBER
76	6 x 12mm	4 x 10mm	1 x 7mm	3 x 8mm	35	32R76NF

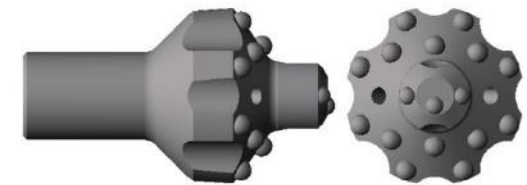

DIA	GAUGE CARBIDE	FRONT CARBIDE	SIDE FLUS.	FACE FLUSHING	GAUGE ANGLE	PART NUMBER
89	8 x 12mm	3 x 10mm	-	2 x 10mm	35	32R89REA
102	14 x 12mm	3 x 10mm	-	2 x 10mm	35	32R102REA
115	14 x 12mm	3 x 10mm	-	2 x 10mm	35	32R115REA
127	14 x 14mm	3 x 10mm	-	2 x 10mm	35	32R127REA

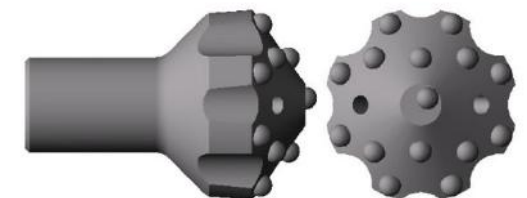

DIA	GAUGE CARBIDE	FRONT CARBIDE	SIDE FLUS.	FACE FLUSHING	GAUGE ANGLE	PART NUMBER
89	8 x 12mm	6 x 12mm	-	2 x 10mm	35	32R89DOM
102	8 x 12mm	8 x 12mm	-	2 x 10mm	35	32R102DOM

TUNNELLING AND DRIFTING

Rods R38/R35 HEX 35mm

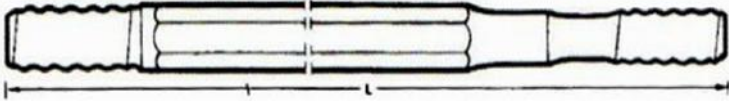

EFF. LENGTH	PART
3700mm	DR3832-3700-H35
4305mm	DR3832-4305-H35
4915mm	DR3832-4915-H35
5525mm	DR3832-5525-H35
6440mm	DR3832-6440-H35

Rods T38/R35 HEX 35mm

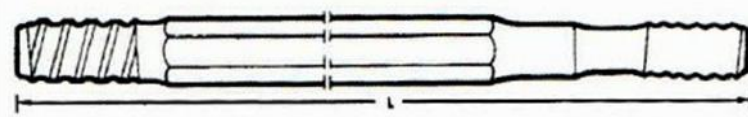

EFF. LENGTH	PART
3700mm	DRT3832-3700-H35
4305mm	DRT3832-4305-H35
4915mm	DRT3832-4915-H35
5525mm	DRT3832-5525-H35
6440mm	DRT3832-6440-H35

Rods T38F/R35M HEX 35mm

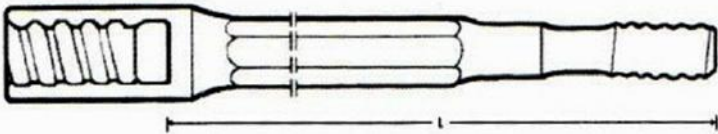

EFF. LENGTH	PART
3700mm	MF3832-3700-H35
4305mm	MF3832-4305-H35
4915mm	MF3832-4915-H35
5525mm	MF3832-5525-H35
6440mm	MF3832-6440-H35

Rods T38/R35 ROUND 39mm

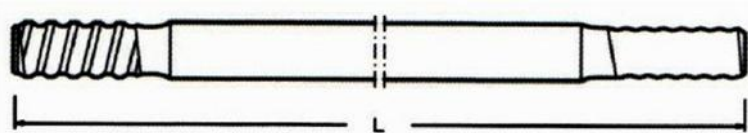

EFF. LENGTH	PART
4305mm	DR3832-4305-39
4915mm	DR3832-4915-39
5525mm	DR3832-5525-39
6440mm	DR3832-6440-39

Rods T38F/R35M ROUND 39mm

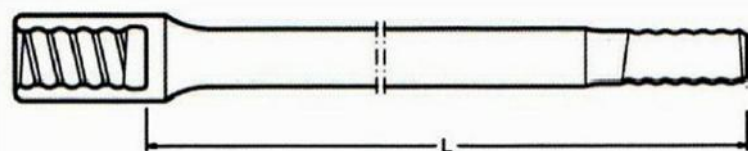

EFF. LENGTH	PART
3700mm	MF3832-3700-39
4305mm	MF3832-4305-39
4915mm	MF3832-4915-39
5525mm	MF3832-5525-39
6440mm	MF3832-6440-39

TUNNELLING AND DRIFTING

BUTTON BITS R35



DIA	GAUGE CARBIDE	FRONT CARBIDE	SIDE FLUSHING	FACE FLUSHING	GAUGE ANGLE	PART NUMBER
48	6 x 10mm	3 x 9mm	1 x 6mm	3 x 5mm	35	35R48ND
51	6 x 10mm	3 x 9mm	1 x 6mm	3 x 5mm	35	35R51ND
64	6 x 11mm	3 x 10mm	1 x 7mm	3 x 8mm	35	35R64ND

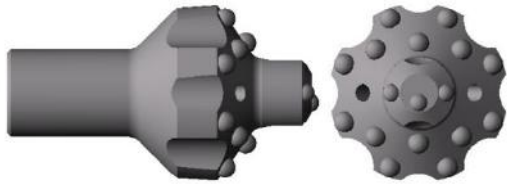

DIA	GAUGE CARBIDE	FRONT CARBIDE	SIDE FLUS.	FACE FLUS-HING	GAUGE ANGLE	PART NUMBER
89	8 x 12mm	3 x 10mm	-	2 x 10mm	35	35R89REA
102	14 x 12mm	3 x 10mm	-	2 x 10mm	35	35R102REA
115	14 x 12mm	3 x 10mm	-	2 x 10mm	35	35R115REA
127	14 x 14mm	3 x 10mm	-	2 x 10mm	35	35R127REA

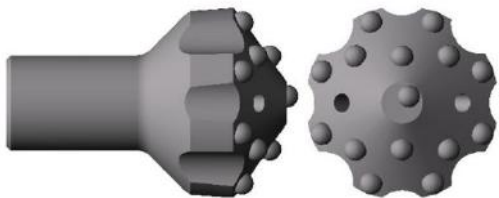

DIA	GAUGE CARBIDE	FRONT CARBIDE	SIDE FLUS.	FACE FLUSHING	GAUGE ANGLE	PART NUMBER
89	8 x 12mm	6 x 12mm	-	2 x 10mm	35	35R89DOM
102	8 x 12mm	8 x 12mm	-	2 x 10mm	35	35R102DOM

EXTENSION DRILLING

Rods R25 HEX 25mm



EFF. LENGTH	PART
610mm	H25 R25 610
915mm	H25 R25 915
1220mm	H25 R25 1220
1525mm	H25 R25 1525
1830mm	H25 R25 1830
2430mm	H25 R25 2430
3050mm	H25 R25 3050
3660mm	H25 R25 3660

COUPLINGS

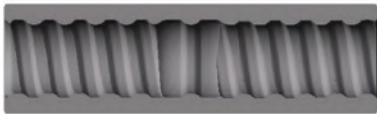

DIA (mm)	LENGTH	DESCR	PART
35	149	R25 SB CPL	CPLR25-35

EXTENSION DRILLING

BUTTON BITS R25



DIA .	GAUGE CARBIDE	FRONT CARBIDE	SIDE FLUSHING	FACE FLUSHING	GAUGE ANGLE	PART NUMBER
33	5 x 7mm	2 x 7mm	2 x 5mm	1 x 5mm	35	25R33NF
35	5 x 8mm	2 x 7mm	2 x 5mm	1 x 5mm	35	25R35NF
37	5 x 9mm	2 x 7mm	2 x 5mm	1 x 5mm	35	25R37NF
38	5 x 9mm	2 x 7mm	2 x 5mm	1 x 5mm	35	25R38NF
41	5 x 9mm	2 x 8mm	2 x 5mm	1 x 5mm	35	25R41NF
45	5 x 10mm	2 x 9mm	2 x 6mm	1 x 6mm	35	25R45NF
48	5 x 10mm	2 x 9mm	2 x 6mm	1 x 5mm	35	25R48NF



DIA .	GAUGE CARBIDE	FRONT CARBIDE	SIDE FLUSHING	FACE FLUSHING	GAUGE ANGLE	PART NUMBER
33	6 x 7mm	2 x 7mm	1 x 5mm	2 x 5mm	35	25R33NF8
35	6 x 7mm	2 x 7mm	1 x 5mm	2 x 5mm	35	25R35NF8
37	6 x 8mm	2 x 7mm	1 x 5mm	2 x 5mm	35	25R37NF8
38	6 x 8mm	2 x 7mm	1 x 5mm	2 x 5mm	35	25R38NF8
41	6 x 8mm	2 x 8mm	1 x 5mm	2 x 5mm	35	25R41NF8
45	6 x 9mm	2 x 8mm	1 x 6mm	2 x 6mm	35	25R45NF8
48	6 x 10mm	2 x 9mm	1 x 6mm	2 x 6mm	35	25R48NF8



DIA .	GAUGE CARBIDE	FRONT CARBIDE	SIDE FLUSHING	FACE FLUSHING	GAUGE ANGLE	PART NUMBER
38	6 x 8mm	3 x 7mm	1 x 5mm	3 x 5mm	35	25R38NG
45	6 x 9mm	3 x 7mm	1 x 5mm	3 x 5mm	35	25R45NG
48	6 x 10mm	3 x 9mm	1 x 6mm	3 x 5mm	35	25R48NG
51	6 x 10mm	3 x 9mm	1 x 6mm	3 x 5mm	35	25R51NG

EXTENSION DRILLING

BUTTON BITS R28



DIA .	GAUGE CARBIDE	FRONT CARBIDE	SIDE FLUSHING	FACE FLUSHING	GAUGE ANGLE	PART NUMBER
37	5 x 9mm	2 x 7mm	2 x 5mm	1 x 5mm	35	28R37NF
38	5 x 9mm	2 x 7mm	2 x 5mm	1 x 5mm	35	28R38NF
41	5 x 9mm	2 x 8mm	2 x 5mm	1 x 5mm	35	28R41NF
45	5 x 10mm	2 x 9mm	2 x 6mm	1 x 6mm	35	28R45NF
48	5 x 10mm	2 x 9mm	2 x 6mm	1 x 6mm	35	28R48NF



DIA .	GAUGE CARBIDE	FRONT CARBIDE	SIDE FLUSHING	FACE FLUSHING	GAUGE ANGLE	PART NUMBER
37	6 x 8mm	2 x 7mm	1 x 5mm	2 x 5mm	35	28R37NF8
38	6 x 8mm	2 x 7mm	1 x 5mm	2 x 5mm	35	28R38NF8
41	6 x 8mm	2 x 8mm	1 x 5mm	2 x 5mm	35	28R41NF8
45	6 x 9mm	2 x 8mm	1 x 6mm	2 x 6mm	35	28R45NF8
48	6 x 10mm	2 x 9mm	1 x 6mm	2 x 6mm	35	28R48NF8



DIA .	GAUGE CARBIDE	FRONT CARBIDE	SIDE FLUSHING	FACE FLUSHING	GAUGE ANGLE	PART NUMBER
38	6 x 8mm	3 x 7mm	1 x 5mm	3 x 5mm	35	28R38NG
45	6 x 9mm	3 x 8mm	1 x 5mm	3 x 5mm	35	28R45NG
48	6 x 10mm	3 x 9mm	1 x 6mm	3 x 5mm	35	28R48NG
51	6 x 10mm	3 x 9mm	1 x 6mm	3 x 5mm	35	28R51NG

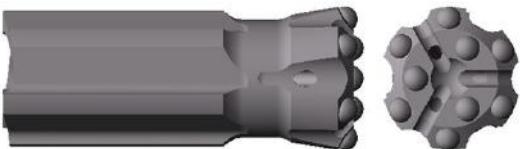

DIA .	GAUGE CARBIDE	FRONT CARBIDE	SIDE FLUSHING	FACE FLUSHING	GAUGE ANGLE	PART NUMBER
45	6 x 9mm	3 x 8mm	-	3 x 5mm	35	28R45RD

EXTENSION DRILLING

Rods R32 ROUND 32mm

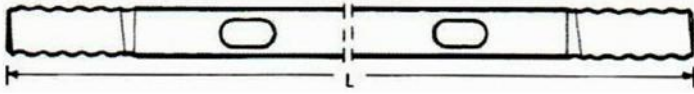

EFF. LENGTH	PART
1220mm	EX3232-1220-32
1525mm	EX3232-1525-32
1830mm	EX3232-1830-32
2430mm	EX3232-2430-32
3050mm	EX3232-3050-32
3660mm	EX3232-3660-32

MF rods R32 ROUND 32mm

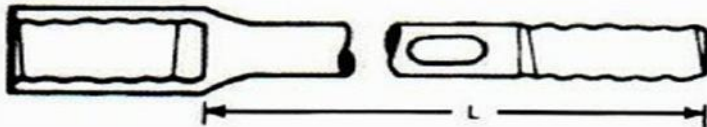

EFF. LENGTH	PART
1220mm	MF3232-1220-32
1525mm	MF3232-1525-32
1830mm	MF3232-1830-32
2430mm	MF3232-2430-32
3050mm	MF3232-3050-32
3660mm	MF3232-3660-32
4270mm	MF3232-4270-32

MF GUIDE RODS R32 ROUND 44mm

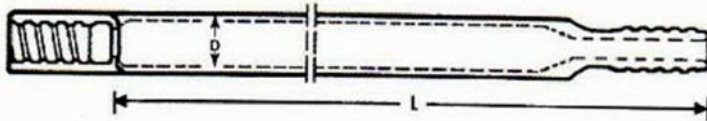

EFF. LENGTH	PART
3050mm	MF3232-3050-44
3660mm	MF3232-3660-44
4270mm	MF3232-4270-44

COUPLINGS

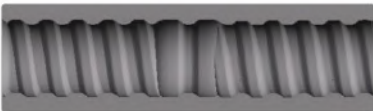

DIA (mm)	LENGTH	DESCR	PART
45	159	R32 SB CPL	CPLR32-45

EXTENSION DRILLING

BUTTON BITS R32

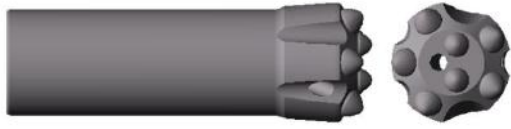

DIA .	GAUGE CARBIDE	FRONT CARBIDE	SIDE FLUSHING	FACE FLUSHING	GAUGE ANGLE	PART NUMBER
45	5 x 10mm	2 x 9mm	2 x 6mm	1 x 6mm	35	32R45NF
48	5 x 10mm	2 x 9mm	2 x 6mm	1 x 6mm	35	32R48NF
51	5 x 10mm	2 x 9mm	2 x 6mm	1 x 6mm	35	32R51NF



DIA .	GAUGE CARBIDE	FRONT CARBIDE	SIDE FLUSHING	FACE FLUSHING	GAUGE ANGLE	PART NUMBER
41	6 x 8mm	2 x 8mm	1 x 5mm	2 x 5mm	35	32R41NF8
43	6 x 9mm	2 x 8mm	1 x 5mm	2 x 5mm	35	32R43NF8



DIA .	GAUGE CARBIDE	FRONT CARBIDE	SIDE FLUSHING	FACE FLUSHING	GAUGE ANGLE	PART NUMBER
45	6 x 9mm	3 x 8mm	1 x 5mm	3 x 5mm	35	32R45NG



DIA .	GAUGE CARBIDE	FRONT CARBIDE	SIDE FLUSHING	FACE FLUSHING	GAUGE ANGLE	PART NUMBER
48	6 x 10mm	3 x 9mm	1 x 6mm	3 x 5mm	35	32R48ND
51	6 x 10mm	3 x 9mm	1 x 6mm	3 x 5mm	35	32R51ND
64	6 x 11mm	3 x 10mm	1 x 7mm	3 x 8mm	35	32R64ND



DIA .	GAUGE CARBIDE	FRONT CARBIDE	SIDE FLUSHING	FACE FLUSHING	GAUGE ANGLE	PART NUMBER
57	6 x 10mm	3 x 9mm	1 x 8mm	1 x 8mm	35	32R57NF

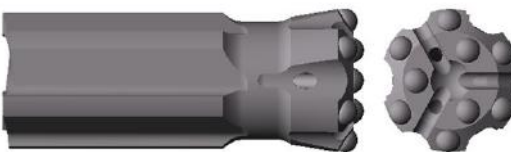

DIA .	GAUGE CARBIDE	FRONT CARBIDE	SIDE FLUSHING	FACE FLUSHING	GAUGE ANGLE	PART NUMBER
48	6 x 10mm	3 x 9mm	-	3 x 5mm	35	32R48RD
51	6 x 10mm	3 x 9mm	-	3 x 5mm	35	32R51RD
64	6 x 11mm	3 x 10mm	1 x 7mm	3 x 8mm	35	32R64RD

EXTENSION DRILLING

BUTTON BITS R32

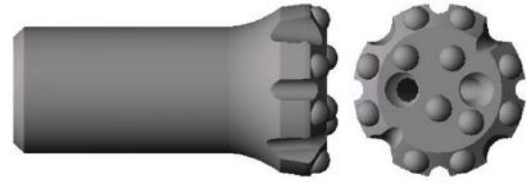

DIA	GAUGE CARBIDE	FRONT CARBIDE	SIDE FLUSHING	FACE FLUSHING	GAUGE ANGLE	PART NUMBER
64	8 x 10mm	4 x 10mm	1 x 7mm	2 x 9mm	35	32R64NF

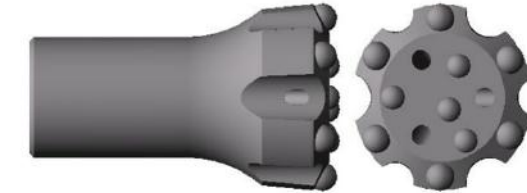

DIA	GAUGE CARBIDE	FRONT CARBIDE	SIDE FLUSHING	FACE FLUSHING	GAUGE ANGLE	PART NUMBER
76	6 x 12mm	4 x 10mm	1 x 7mm	3 x 8mm	35	32R76NF

EXTENSION DRILLING

RODS T38 HEX 32mm

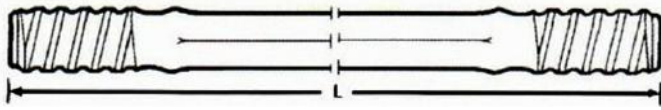

EFF. LENGTH	PART
3050mm	EX3838-3050-32
3660mm	EX3838-3660-32
4270mm	EX3838-4270-32

RODS T38 ROUND 39mm

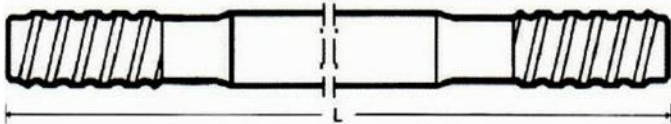

EFF. LENGTH	PART
1220mm	EX3838-1220-39
1525mm	EX3838-1525-39
1830mm	EX3838-1830-39
2430mm	EX3838-2430-39
3050mm	EX3838-3050-39
3660mm	EX3838-3660-39
4270mm	EX3838-4270-39
4905mm	EX3838-4905-39

MF RODS T38 ROUND 39mm

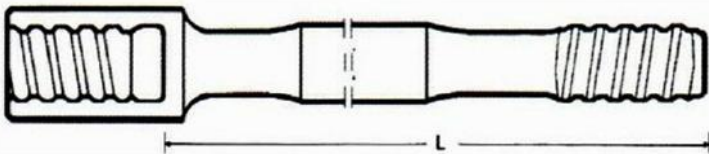

EFF. LENGTH	PART
1220mm	MF3838-1220-39
1525mm	MF3838-1525-39
1830mm	MF3838-1830-39
2430mm	MF3838-2430-39
3050mm	MF3838-3050-39
3660mm	MF3838-3660-39
4270mm	MF3838-4270-39
4905mm	MF3838-4905-39

MF GUIDE RODS T38 ROUND 55mm

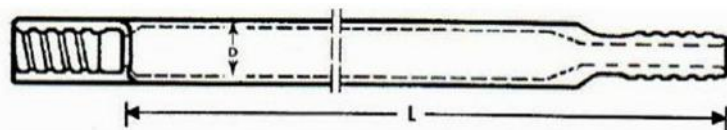

EFF. LENGTH	PART
1220mm	MF3838-1220-55
1525mm	MF3838-1525-55
1830mm	MF3838-1830-55
2430mm	MF3838-2430-55
3050mm	MF3838-3050-55

COUPLINGS

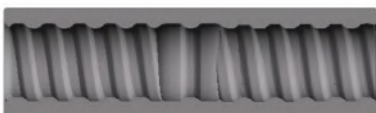

DIA (mm)	LENGTH	DESCR	PART
55	190	T38 SB CPL	CPLT38-55

EXTENSION DRILLING

BUTTON BITS T38

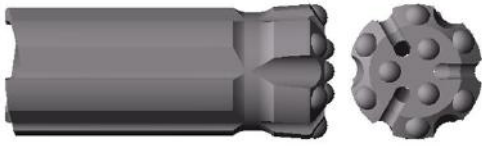

DIA .	GAUGE CARBIDE	FRONT CARBIDE	SIDE FLUSHING	FACE FLUSHING	GAUGE ANGLE	PART NUMBER
54	6 x 10mm	3 x 9mm	-	3 x 6mm	35	38T54RG



DIA .	GAUGE CARBIDE	FRONT CARBIDE	SIDE FLUSHING	FACE FLUSHING	GAUGE ANGLE	PART NUMBER
64	8 x 10mm	4 x 10mm	1 x 7mm	2 x 9mm	35	38T64NF

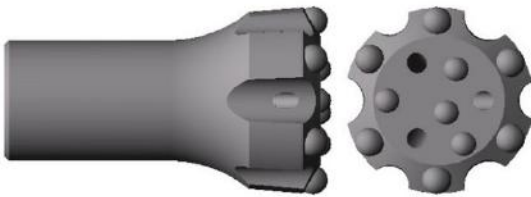

DIA .	GAUGE CARBIDE	FRONT CARBIDE	SIDE FLUSHING	FACE FLUSHING	GAUGE ANGLE	PART NUMBER
76	6 x 12mm	4 x 10mm	1 x 7mm	3 x 8mm	35	38T76NF

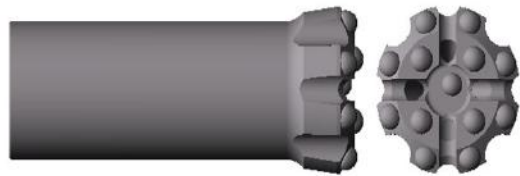

DIA .	GAUGE CARBIDE	FRONT CARBIDE	SIDE FLUSHING	FACE FLUSHING	GAUGE ANGLE	PART NUMBER
64	8 x 10mm 4 x 10mm,	1 x 8mm	-	4 x 8mm	35	38T64ND
70	8 x 11mm	5 x 10mm	-	4 x 7mm	35	38T70ND
76	8 x 12mm	5 x 11mm	-	4 x 8mm	35	38T76ND



DIA .	GAUGE CARBIDE	FRONT CARBIDE	SIDE FLUSHING	FACE FLUSHING	GAUGE ANGLE	PART NUMBER
64	8 x 10mm 4 x 10mm,	1 x 8mm	-	4 x 8mm	35	38T64RD
70	8 x 11mm	5 x 10mm	-	4 x 7mm	35	38T70RD

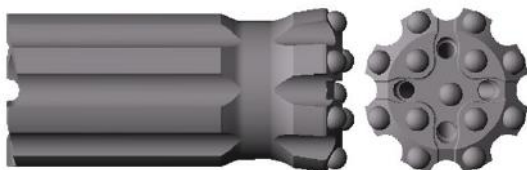

DIA .	GAUGE CARBIDE	FRONT CARBIDE	SIDE FLUSHING	FACE FLUSHING	GAUGE ANGLE	PART NUMBER
76	8 x 12mm	5 x 11mm	-	4 x 8mm	35	38T76RD

EXTENSION DRILLING

BUTTON BITS T38

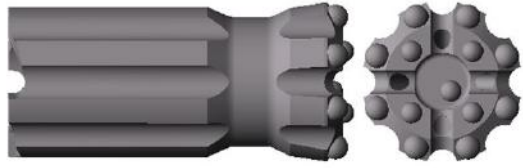

DIA	GAUGE CARBIDE	FRONT CARBIDE	SIDE FLUSHING	FACE FLUSHING	GAUGE ANGLE	PART NUMBER
83	8 x 13mm	5 x 11mm	-	4 x 8mm	35	38T83RD

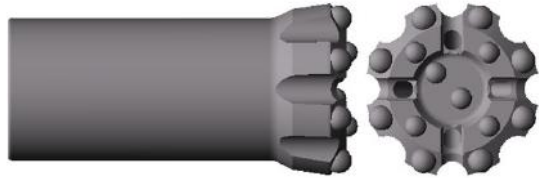

DIA	GAUGE CARBIDE	FRONT CARBIDE	SIDE FLUSHING	FACE FLUSHING	GAUGE ANGLE	PART NUMBER
89	8 x 13mm	6 x 11mm	-	4 x 8mm	35	38T89ND
102	8 x 14mm	6 x 12mm	-	4 x 9mm	35	38T102ND

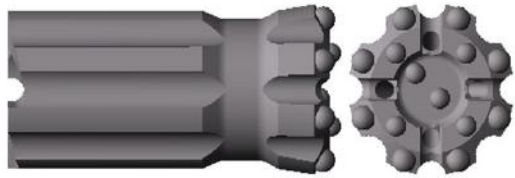

DIA	GAUGE CARBIDE	FRONT CARBIDE	SIDE FLUSHING	FACE FLUSHING	GAUGE ANGLE	PART NUMBER
89	8 x 13mm	6 x 11mm	-	4 x 8mm	35	38T89RD
102	8 x 14mm	6 x 12mm	-	4 x 9mm	35	38T102RD

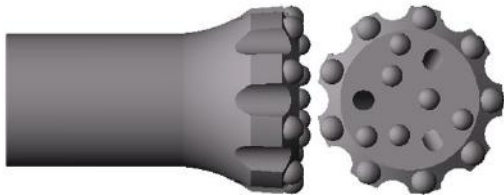

DIA	GAUGE CARBIDE	FRONT CARBIDE	SIDE FLUSHING	FACE FLUSHING	GAUGE ANGLE	PART NUMBER
102	9 x 14mm	6 x 12mm	-	3 x 12mm	40	38T102NF

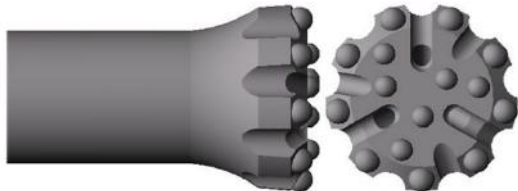

DIA	GAUGE CARBIDE	FRONT CARBIDE	SIDE FLUSHING	FACE FLUSHING	GAUGE ANGLE	PART NUMBER
102	9 x 14mm	6 x 12mm	-	3 x 12mm	40	38T102NG

EXTENSION DRILLING

RODS T45 HEX 38mm

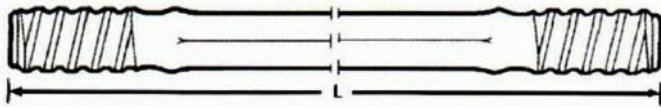

EFF. LENGTH	PART
3050mm	EX4545-3050-38
3660mm	EX4545-3660-38
4270mm	EX4545-4270-38

RODS T45ROUND 45mm

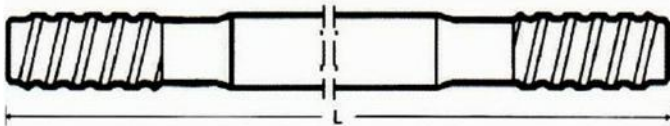

EFF. LENGTH	PART
1220mm	EX4545-1220-45
1525mm	EX4545-1525-45
1830mm	EX4545-1830-45
2430mm	EX4545-2430-45
3050mm	EX4545-3050-45
3660mm	EX4545-3660-45
4270mm	EX4545-4270-45
4905mm	EX4545-4905-45

MF RODS T45 ROUND 45mm

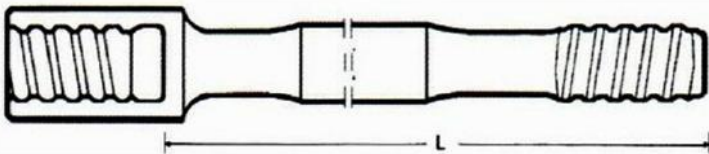

EFF. LENGTH	PART
1220mm	MF4545-1220-45
1525mm	MF4545-1525-45
1830mm	MF4545-1830-45
2430mm	MF4545-2430-45
3050mm	MF4545-3050-45
3660mm	MF4545-3660-45
4270mm	MF4545-4270-45
4905mm	MF4545-4905-45

MF GUIDE RODS T38 ROUND 64mm



EFF. LENGTH	PART
1220mm	MF4545-1220-64
1525mm	MF4545-1525-64
1830mm	MF4545-1830-64
2430mm	MF4545-2430-64
3050mm	MF4545-3050-64

COUPLINGS

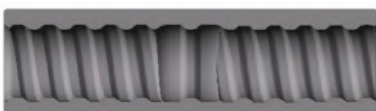

DIA (mm)	LENGTH	DESCR	PART
63	207	T45 SB	CPLT45-63

EXTENSION DRILLING

BUTTON BITS T45

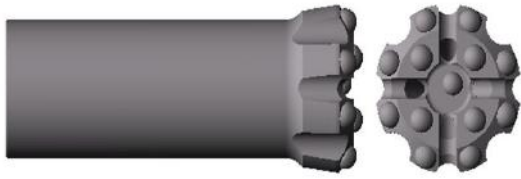

DIA	GAUGE CARBIDE	FRONT CARBIDE	SIDE FLUSHING	FACE FLUSHING	GAUGE ANGLE	PART NUMBER
66	8 x 10mm 4 x 10mm.	1 x 8mm	-	4 x 8mm	35	45T66ND
70	8 x 11mm	5 x 10mm	-	4 x 7mm	35	45T70ND
76	8 x 12mm	5 x 11mm	-	4 x 8mm	35	45T76ND



DIA	GAUGE CARBIDE	FRONT CARBIDE	SIDE FLUSHING	FACE FLUSHING	GAUGE ANGLE	PART NUMBER
76	6 x 12mm	4 x 10mm	1 x 7mm	3 x 8mm	35	45T76NF



DIA	GAUGE CARBIDE	FRONT CARBIDE	SIDE FLUSHING	FACE FLUSHING	GAUGE ANGLE	PART NUMBER
66	8 x 10mm 4 x 10mm.	1 x 8mm	-	4 x 8mm	35	45T66RD
70	8 x 11mm	5 x 10mm	-	4 x 7mm	35	45T70RD

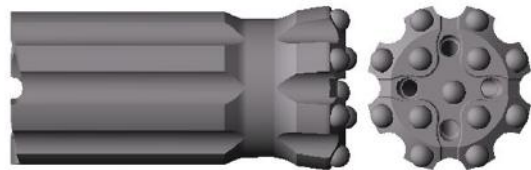

DIA	GAUGE CARBIDE	FRONT CARBIDE	SIDE FLUSHING	FACE FLUSHING	GAUGE ANGLE	PART NUMBER
76	8 x 12mm	5 x 11mm	-	4 x 8mm	35	45T76RD



DIA	GAUGE CARBIDE	FRONT CARBIDE	SIDE FLUSHING	FACE FLUSHING	GAUGE ANGLE	PART NUMBER
83	8 x 13mm	5 x 11mm	-	4 x 8mm	35	45T83RD

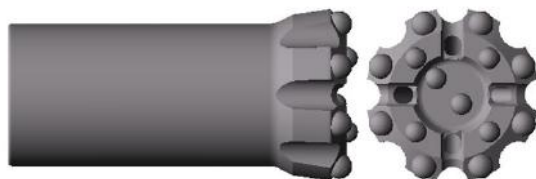

DIA	GAUGE CARBIDE	FRONT CARBIDE	SIDE FLUSHING	FACE FLUSHING	GAUGE ANGLE	PART NUMBER
89	8 x 13mm	6 x 11mm	-	4 x 8mm	35	45T89ND
102	8 x 14mm	6 x 12mm	-	4 x 9mm	35	45T102ND

EXTENSION DRILLING

BUTTON BITS T45

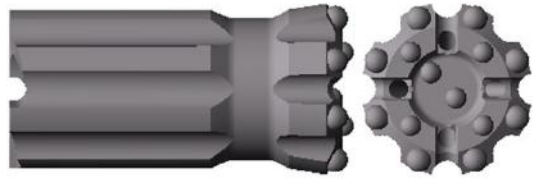

DIA	GAUGE CARBIDE	FRONT CARBIDE	SIDE FLUSHING	FACE FLUSHING	GAUGE ANGLE	PART NUMBER
89	8 x 13mm	6 x 11mm	-	4 x 8mm	35	45T89RD
102	8 x 14mm	6 x 12mm	-	4 x 9mm	35	45T102RD

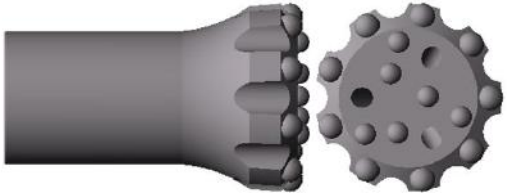

DIA	GAUGE CARBIDE	FRONT CARBIDE	SIDE FLUSHING	FACE FLUSHING	GAUGE ANGLE	PART NUMBER
102	9 x 14mm	6 x 12mm	-	3 x 12mm	40	45T102NF

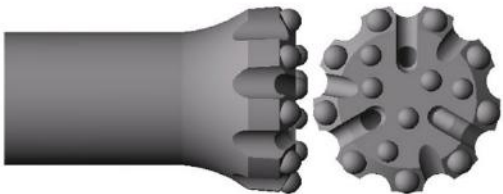

DIA	GAUGE CARBIDE	FRONT CARBIDE	SIDE FLUS.	FACE FLUSHING	GAUGE ANGLE	PART NUMBER
102	9 x 14mm	6 x 12mm	-	3 x 12mm	40	45T102NG

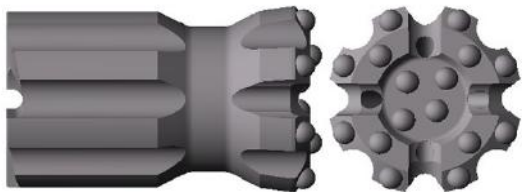

DIA	GAUGE CARBIDE	FRONT CARBIDE	SIDE FLUS.	FACE FLUSHING	GAUGE ANGLE	PART NUMBER
115	8 x 14mm	4 x 14mm	-	4 x 11mm	35	45T115RD

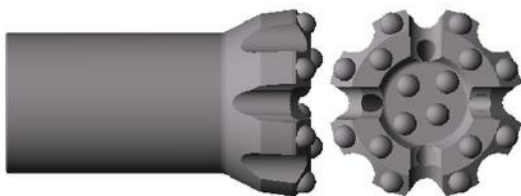

DIA	GAUGE CARBIDE	FRONT CARBIDE	SIDE FLUSHING	FACE FLUSHING	GAUGE ANGLE	PART NUMBER
115	8 x 14mm	4 x 14mm	-	4 x 11mm	35	45T115ND

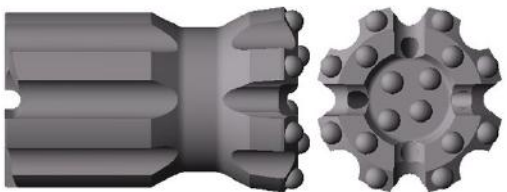

DIA.	GAUGE CARBIDE	FRONT CARBIDE	SIDE FLUSHING	FACE FLUSHING	GAUGE ANGLE	PART NUMBER
127	10 x 14mm	9 x 14mm	-	5 x 11mm	35	45T127RD

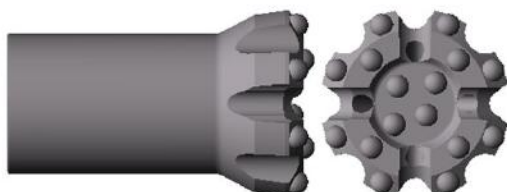

DIA	GAUGE CARBIDE	FRONT CARBIDE	SIDE FLUSHING	FACE FLUSHING	GAUGE ANGLE	PART NUMBER
127	10 x 14mm	9 x 14mm	-	5 x 11mm	35	45T127ND

EXTENSION DRILLING

RODS T51ROUND 51mm



EFF. LENGTH	PART
1220mm	EX5151-1220-51
1525mm	EX5151-1525-51
1830mm	EX5151-1830-51
2430mm	EX5151-2430-51
3050mm	EX5151-3050-51
3660mm	EX5151-3660-51
4270mm	EX5151-4270-51
4905mm	EX5151-4905-51

MF RODS T51 ROUND 51mm

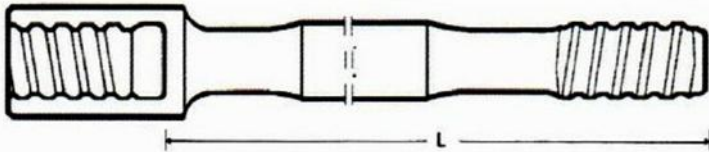

EFF. LENGTH	PART
1220mm	MF5151-1220-51
1525mm	MF5151-1525-51
1830mm	MF5151-1830-51
2430mm	MF5151-2430-51
3050mm	MF5151-3050-51
3660mm	MF5151-3660-51
4270mm	MF5151-4270-51
4905mm	MF5151-4905-51

MF GUIDE RODS T51 ROUND 76mm

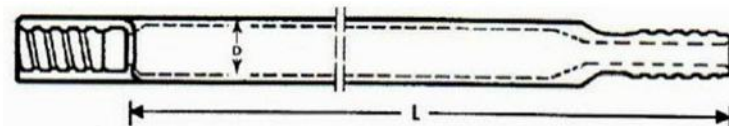

EFF. LENGTH	PART
1220mm	MF5151-1220-76
1525mm	MF5151-1525-76
1830mm	MF5151-1830-76
2430mm	MF5151-2430-76
3050mm	MF5151-3050-76

COUPLINGS

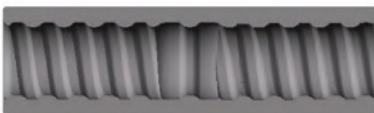

DIA (mm)	LENGTH	DESCR	PART
72	234	T51 SB CPL	CPLT51-72

EXTENSION DRILLING

BUTTON BITS T51

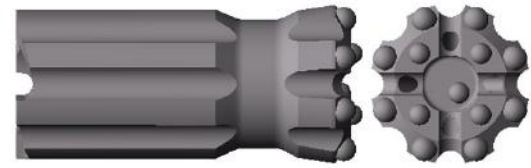

DIA	GAUGE CARBIDE	FRONT CARBIDE	SIDE FLUSHING	FACE FLUSHING	GAUGE ANGLE	PART NUMBER
83	8 x 13mm	5 x 11mm	-	4 x 8mm	35	51T83RD

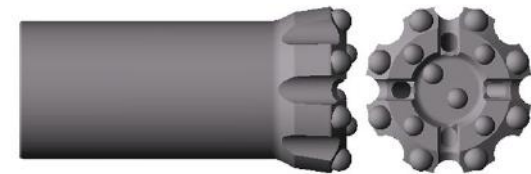

DIA	GAUGE CARBIDE	FRONT CARBIDE	SIDE FLUSHING	FACE FLUSHING	GAUGE ANGLE	PART NUMBER
89	8 x 13mm	6 x 11mm	-	4 x 8mm	35	51T89ND
102	8 x 14mm	6 x 12mm	-	4 x 9mm	35	51T102ND

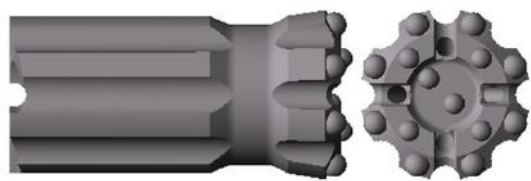

DIA	GAUGE CARBIDE	FRONT CARBIDE	SIDE FLUSHING	FACE FLUSHING	GAUGE ANGLE	PART NUMBER
89	8 x 13mm	6 x 11mm	-	4 x 8mm	35	51T89RD
102	8 x 14mm	6 x 12mm	-	4 x 9mm	35	51T102RD

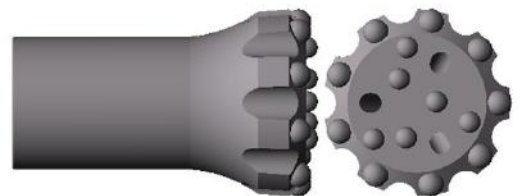

DIA	GAUGE CARBIDE	FRONT CARBIDE	SIDE FLUSHING	FACE FLUSHING	GAUGE ANGLE	PART NUMBER
102	9 x 14mm	6 x 12mm	-	3 x 12mm	40	51T102NF

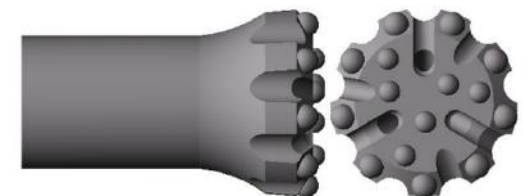

DIA	GAUGE CARBIDE	FRONT CARBIDE	SIDE FLUSHING	FACE FLUSHING	GAUGE ANGLE	PART NUMBER
102	9 x 14mm	6 x 12mm	-	3 x 12mm	40	51T102NG

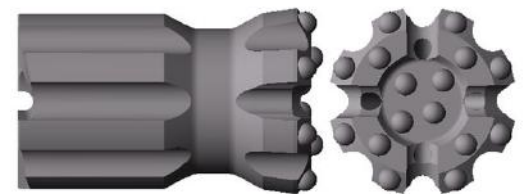

DIA	GAUGE CARBIDE	FRONT CARBIDE	SIDE FLUSHING	FACE FLUSHING	GAUGE ANGLE	PART NUMBER
115	8 x 14mm	4 x 14mm	-	4 x 11mm	35	51T115RD

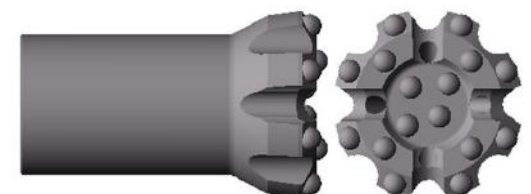

DIA	GAUGE CARBIDE	FRONT CARBIDE	SIDE FLUSHING	FACE FLUSHING	GAUGE ANGLE	PART NUMBER
115	8 x 14mm	4 x 14mm	-	4 x 11mm	35	51T115ND

EXTENSION DRILLING

BUTTON BITS T51

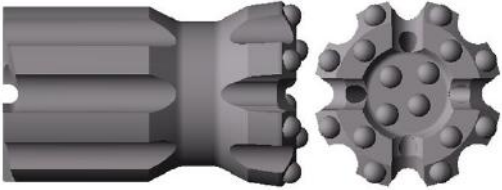

DIA.	GAUGE CARBIDE	FRONT CARBIDE	SIDE FLUSHING	FACE FLUSHING	GAUGE ANGLE	PART NUMBER
127	10 x 14nn	9 x 14mm	-	5 x 11mm	35	51T127RD

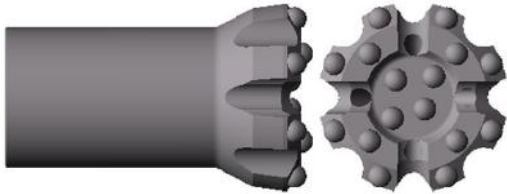

DIA	GAUGE CARBIDE	FRONT CARBIDE	SIDE FLUSHING	FACE FLUSHING	GAUGE ANGLE	PART NUMBER
127	10 x 14nn	9 x 14mm	-	5 x 11mm	35	51T127ND

EXTENSION DRILLING

MF RODS T60 ROUND 60mm

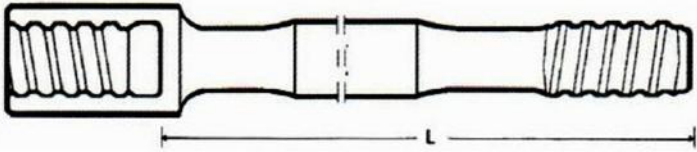

EFF. LENGTH	PART
3050mm	MF6060-3050-60
3660mm	MF6060-3660-60
4270mm	MF6060-4270-60
4905mm	MF6060-4905-60

MF GUIDE RODS T60 ROUND

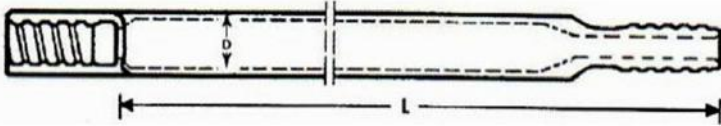

EFF. LENGTH	PART
3660mm	MF6060-3660-G
4270mm	MF6060-4270-G

MF RODS MT60 ROUND 82mm

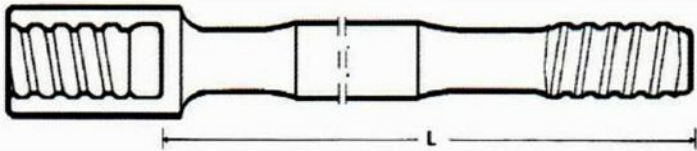

EFF. LENGTH	PART
3050mm	MT6060-3050-82
3660mm	MT6060-3660-82
4270mm	MT6060-4270-82
4905mm	MT6060-4905-82

MF RODS MT60 ROUND 85mm

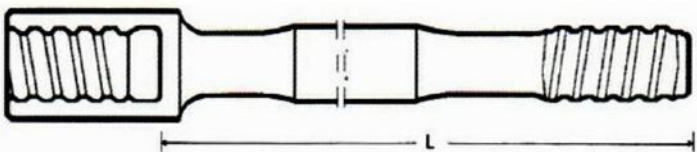

EFF. LENGTH	PART
3050mm	MT6060-3050-85
3660mm	MT6060-3660-85
4270mm	MT6060-4270-85
4905mm	MT6060-4905-85

MF GUIDE RODS MT60 ROUND 87mm

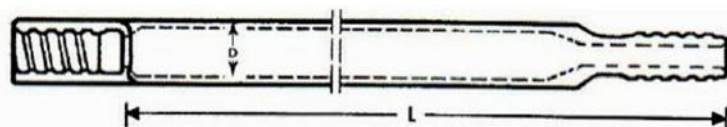

4265mm	MT6060-4270-G
--------	---------------

EXTENSION DRILLING

BUTTON BITS MT60

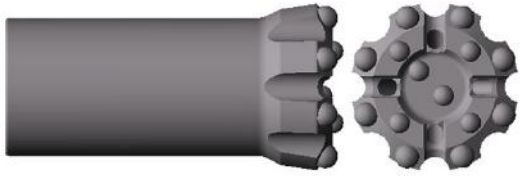

DIA.	GAUGE CARBIDE	FRONT CARBIDE	SIDE FLUSHING	FACE FLUSHING	GAUGE ANGLE	PART NUMBER
102	8 x 14mm	6 x 12mm	-	4 x 9mm	35	60MT102ND

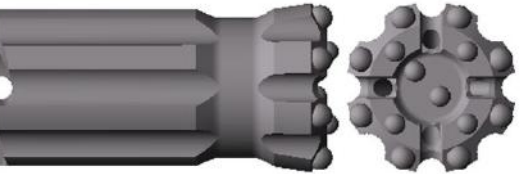

DIA.	GAUGE CARBIDE	FRONT CARBIDE	SIDE FLUSHING	FACE FLUSHING	GAUGE ANGLE	PART NUMBER
102	8 x 14mm	6 x 12mm	-	4 x 9mm	35	60MT102RD

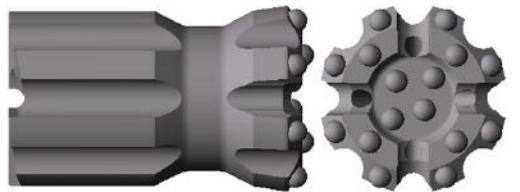

DIA.	GAUGE CARBIDE	FRONT CARBIDE	SIDE FLUSHING	FACE FLUSHING	GAUGE ANGLE	PART NUMBER
115	8 x 14nn	4 x 14mm	-	4 x 11mm	35	60MT115RD

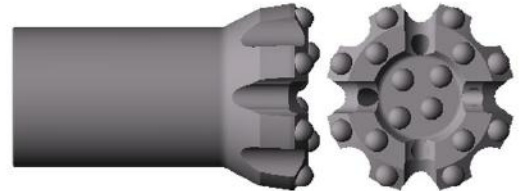

DIA.	GAUGE CARBIDE	FRONT CARBIDE	SIDE FLUS.	FACE FLUSHING	GAUGE ANGLE	PART NUMBER
115	8 x 14nn	4 x 14mm	-	4 x 11mm	35	60MT115ND

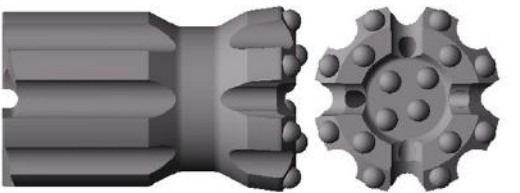

DIA.	GAUGE CARBIDE	FRONT CARBIDE	SIDE FLUS.	FACE FLUSHING	GAUGE ANGLE	PART NUMBER
127	10 x 14nn	9 x 14mm	-	5 x 11mm	35	60MT127RD

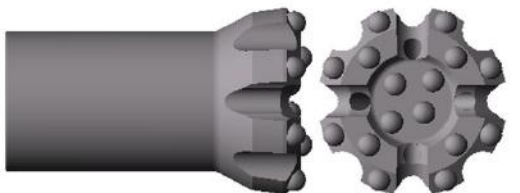

DIA.	GAUGE CARBIDE	FRONT CARBIDE	SIDE FLUSHING	FACE FLUSHING	GAUGE ANGLE	PART NUMBER
127	10 x 14nn	9 x 14mm	-	5 x 11mm	35	60MT127ND

SHANK ADAPTORS

ATLAS COPCO

THREAD	DESCRIPTION	LENGTH
T38	A/C BBE57,MONT H100	537
T45	A/C BBE57,MONT H100	537
R32	A/COPCO COP125,130,131	405
T38	A/COPCO COP125,130,131	381
T38	A/COPCO COP131EB	381
R28	A/COPCO 1028HB	400
R32	A/COPCO 1028HB	400
R38	A/C COP1038 HD,1038 HL	485
T38	A/C COP1038 HD,COP1238	485
T38	A/COPCO COP1038HL,1238	500
T45	A/COPCO COP1038HL,1238	500
R32	A/COPCO COP1038HL,1238	575
T38	A/COPCO COP1038HL,1238	575
T45	A/COPCO COP1038HL,1238	575
T45	A/COPCO COP1038HL,1238	590
R32	A/COPCO COP1038(COLLAR)	575
T38	A/COPCO COP1038(COLLAR)	575
R32	A/C COP1036HB,1038HB,1238 (COLLAR)	575
R38	A/C COP1036HB,1038HB,1238 (COLLAR)	575
T38	A/C COP1036HB,1038HB,1238 (COLLAR)	575
T45	A/C COP1036HB,1038HB,1238 (COLLAR)	575
R28	A/C COP1132	410
R32	A/C COP1132	410
T35	A/C COP1132	410
R32	A/C COP1132	500
T35	A/C COP1132	500
R32F	A/C COP1132 (Female)	280
R32F	A/C COP1432, COP1532 FEMALE	341
R38F	A/C COP1432, COP1532 FEMALE	341
T38F	A/C COP1432, COP1532 FEMALE	341
R32	COP1338 EXTRACTOR	780
T38	COP1338 EXTRACTOR	780
T45	COP1338 EXTRACTOR	780
R32	ATLAS COPCO COP1435	500

SHANK ADAPTORS

ATLAS COPCO

THREAD	DESCRIPTION	LENGTH
T35	ATLAS COPCO COP1435	500
R32	A/COPCO COP1440, COP1550, COP1638, COP1838, COP2238	435
T35	A/COPCO COP1440, COP1550, COP1638, COP1838, COP2238	435
R38	A/COPCO COP1440, COP1550, COP1638, COP1838, COP2238	435
T38	A/COPCO COP1440, COP1550, COP1638, COP1838, COP2238	435
R32	A/COPCO COP1440, COP1550, COP1638, COP1838, COP2238	525
T35	A/COPCO COP1440, COP1550, COP1638, COP1838, COP2238	525
R38	A/COPCO COP1440, COP1550, COP1638, COP1838, COP2238	525
T38	A/COPCO COP1440, COP1550, COP1638, COP1838, COP2238	525
R32	A/COPCO COP1440, COP1550, 1838HD (D=52mm)	525
T35	A/COPCO COP1440, COP1550, 1838HD (D=52mm)	525
T38	A/COPCO COP1440, COP1550, 1838HD (D=52mm)	525
T45	A/COPCO COP1440, COP1550, 1838HD (D=52mm)	525
T51	A/COPCO COP1440, COP1550, 1838HD (D=52mm)	525
T38	A/COPCO COP1838MUX	730
T45	A/COPCO COP1838MUX	730
T38	A/COPCO COP 1838EX	730
T45	A/COPCO COP 1838EX	730
T51	A/COPCO COP 1838EX	730
T45	A/COPCO COP 1850, 1840HE, 2150HE	565
T51	A/COPCO COP 1850, 1840HE, 2150HE	565
T51	A/COPCO COP 1850, 1840HE, 2150HE	770
T51	A/COPCO COP 2150/2550 (STRAIGHT SPLINE)	770
T38	COP 1240/1640/1840/1850/2150/2550HEX	770
T45	COP 1240/1640/1840/1850/2150/2550HEX	770
T51	COP 1240/1640/1840/1850/2150/2550HEX	770
T51	A/COPCO COP 2160/2560 EXTRACTOR	770
MT60	A/COPCO COP 2160/2560 EXTRACTOR	770
T38	A/COPCO COP 3038	435
T45	A/COPCO COP 3038	435
T38	A/COPCO COP 3038HE (Helical)	435
T45	A/COPCO COP 3038HE (Helical)	435
T38	A/COPCO COP 3038HE (Helical)	525
T58	ATLAS COPCO COP4050 MUX	835
T68	ATLAS COPCO COP4050 MUX	835

SHANK ADAPTORS

BOART LONGYEAR, CANNON, DOOFOR

THREAD	DESCRIPTION	LENGTH
R32F	BOART HD65 (female)	324
R32	BOART HD65	445
R32	BOART HD125,HD150	495
R38	BOART HD125,HD150	495
T38	BOART HD125,HD150	495
T38F	CANNON CH38 (JOYJH-2)(55mm Body,female)	390
T45	CANNON CH38 (JOYJH-2)(55mm Body,)	525
T38	CANNON CH38 (JOYJH-2) (38mm Body)	444
T38	JOY VCR260 /360	432
R25	DOOFOR DF425/430S	400
R28	DOOFOR DF425/430S	400
R32	DOOFOR DF528	424
R32	DOOFOR DF528HD	470
R38	DOOFOR DF528HD	470
P38	DOOFOR DF528HD	470
R32	DOOFOR DF545	515
R38	DOOFOR DF545	515
T38	DOOFOR DF545	515
R32	DOOFOR DF545HD	515
R38	DOOFOR DF545HD	515
T38	DOOFOR DF545HD	515
T45	DOOFOR DF545HD	515
R32	DOOFOR DF545EXT	582
R38	DOOFOR DF545EXT	582
T38	DOOFOR DF545EXT	582
R32	DOOFOR DF545EXT HD	582
R38	DOOFOR DF545EXT HD	582
T38	DOOFOR DF545EXT HD	582
T45	DOOFOR DF545EXT HD	582

SHANK ADAPTORS

FURUKAWA

THREAD	DESCRIPTION	LENGTH
R38	FURUKAWA PD200(H/D CHUCK)	381
T38	FURUKAWA PD200(H/D CHUCK)	381
T45	FURUKAWA PD200(H/D CHUCK)	381
T38	FURUKAWA HD90	512
R38	FURUKAWA HD150	520
T38	FURUKAWA HD150	520
T38	FURUKAWA HD180	455
R38	FURUKAWA HD190	480
T38	FURUKAWA HD190	480
T38	FURUKAWA HD210	430
T38	FURUKAWA HD260,HD300	655
T45	FURUKAWA HD260,HD300	655
T38	FURUKAWA HD500 (6 SPLINE)	625
T45	FURUKAWA HD500 (6 SPLINE)	625
T38	FURUKAWA HD609	615
T45	FURUKAWA HD609	615
T38	FURUKAWA HD609	690
T45	FURUKAWA HD609	690
T38	FURUKAWA HD609QED	860
T45	FURUKAWA HD609QED	860
T45	FURUKAWA HD612	710
T51	FURUKAWA HD612	710
T45	FURUKAWA HD612QED	900
T51	FURUKAWA HD612QED	900
T51	FURUKAWA HD615	880
T51	FURUKAWA HD615QED	880
T45	FURUKAWA HD709	620
T45	FURUKAWA HD709QED	800
T45	FURUKAWA HD712	590
T51	FURUKAWA HD712	590
T45	FURUKAWA HD712	790
T51	FURUKAWA HD712	790
T45	FURUKAWA HD712QED	880
T51	FURUKAWA HD712QED	880
T51	FURUKAWA HD715	790
T51	FURUKAWA HD715QED	885

SHANK ADAPTORS

I.RAND

THREAD	DESCRIPTION	LENGTH
R32	I/RAND YD90M	330
T38	I/RAND YH65.70,75,80	496
T45	I/RAND YH65.70,75,80	496
T38	I/RAND YH65.70,75,80	700
T45	I/RAND YH65.70,75,80	700
T38	I/RAND YH65RP,80RP	700
T45	I/RAND YH65RP,80RP	700
T45	I/RAND YH80A	500
T45	I/RAND YH 95,100	622
T51	I/RAND YH 95,100	622
T45	I/RAND YH110VRP	900
T51	I/RAND YH110VRP	900

SHANK ADAPTORS

MONTABERT

THREAD	DESCRIPTION	LENGTH
R32F	MONTABERT HC20 (D=45mm) FEMALE	187
R32	MONTABERT HC20 (D=45mm)	287
R32	MONTABERT HC25 (D=45mm)	287
T35	MONTABERT HC25 (D=45mm)	287
R38	MONTABERT HC25 (D=45mm)	287
T38	MONTABERT HC25 (D=45mm)	287
R32	MONTABERT HC25 (D=45mm) FEMALE	202
R32	MONTABERT HC40/HC50 (D=38mm)	438
T35	MONTABERT HC40/HC50 (D=38mm)	438
R38	MONTABERT HC40/HC50 (D=38mm)	438
T38	MONTABERT HC40/HC50 (D=38mm)	438
R32	MONTABERT HC40 FEMALE (D=45mm)	270
R38	MONTABERT HC80, HC90, HC105 (D=38mm)	440
T38	MONTABERT HC80, HC90, HC105 (D=38mm)	440
R38	MONTABERT HC80, HC90, HC105 (D=38mm)	508
T38	MONTABERT HC80, HC90, HC105 (D=38mm)	508
R38	MONTABERT HC80, HC109, HC110, HC120 , (D=45mm)	490
T38	MONTABERT HC80, HC109, HC110, HC120 , (D=45mm)	490
T45	MONTABERT HC80, HC109, HC110, HC120 , (D=45mm)	490
R38	MONTABERT HC80, HC109, HC110, HC120 , (D=45mm)	530
T38	MONTABERT HC80, HC109, HC110, HC120 , (D=45mm)	530
T45	MONTABERT HC80, HC109, HC110, HC120 , (D=45mm)	530
T35	MONTABERT HC80R, HC105R, HC107R, HC108R	670
T38	HC109R, HC110R, HC120R (D=45mm)	670
T45	HC109R, HC110R, HC120R (D=45mm)	670
T45	HC109R, HC110R, HC120R (D=45mm)	770
T45	MONTABERT HC120R, HC150R, HC155R, HC158R (D=51mm)	670
T51	MONTABERT HC120R, HC150R, HC155R, HC158R (D=51mm)	670
T45	MONTABERT HC120R, HC150R, HC155R, HC158R (D=51mm)	770
T51	MONTABERT HC120R, HC150R, HC155R, HC158R (D=51mm)	770
T45	MONTABERT HC160,170	807
T51	MONTABERT HC160,170	807
MT60	MONTABERT HC160,170	807
T51	MONTABERT HC200A	840
T60	MONTABERT HC200A	840
MT60	MONTABERT HC200A	840

SHANK ADAPTORS

SANDVIK TAMROCK

THREAD	DESCRIPTION	LENGTH
R32	TAMROCK HL300S FEMALE	245
R32	TAMROCK HL300	400
R32	TAMROCK L400,L410,L500,L510	381
R38	TAMROCK HLR438,L550	381
T38	TAMROCK HLR438,L550	381
R38	TAMROCK HL438TS,HL538	450
T38	TAMROCK HL438TS,HL538	450
R32	TAMROCK HL438TS,HL538	495
R38	TAMROCK HL438TS,HL538	495
T38	TAMROCK HL438TS,HL538	495
R32	TAMROCK HL500 S, HL510 S (D=38mm)	450
R38	TAMROCK HL500 S, HL510 S (D=38mm)	450
T38	TAMROCK HL500 S, HL510 S (D=38mm)	450
T38	TAMROCK HL500 S, HL510 S (D=38mm)	550
R32	TAMROCK HL500, HL510 (D=45mm)	550
T35	TAMROCK HL500, HL510 (D=45mm)	550
T38	TAMROCK HL500, HL510 (D=45mm)	550
T45	TAMROCK HL500, HL510 (D=45mm)	550
R32	TAMROCK HL500 (FEMALE)	350
T35	TAMROCK HL550 SUPER,560 SUPER	500
R38	TAMROCK HL550 SUPER,560 SUPER	500
T38	TAMROCK HL550 SUPER,560 SUPER	500
T45	TAMROCK HL550 SUPER,560 SUPER	500
R25	TAMROCK HLX1	255
R28	TAMROCK HLX1	255
R32	TAMROCK RD314 (FEMALE)	205
T38	TAMROCK RD520/RD525	525
T35	TAMROCK RD520/RD525	600
T38	TAMROCK RD520/RD525	600
T35	TAMROCK RD520/RD525	745
T38	TAMROCK RD520/RD525	745
R32	TAMROCK HLX5/HFX5T	500
T35	TAMROCK HLX5/HFX5T	500
R38	TAMROCK HLX5/HFX5T	500
T38	TAMROCK HLX5/HFX5T	500
T45	TAMROCK HLX5/HFX5T	500
R32	TAMROCK HLX5/HFX5T	575
T35	TAMROCK HLX5/HFX5T	575
T38	TAMROCK HLX5/HFX5T	575

SHANK ADAPTORS

SANDVIK TAMROCK

THREAD	DESCRIPTION	LENGTH
T45	TAMROCK HLX5/HFX5T	575
T38	TAMROCK HL600 (D=45mm)	525
T45	TAMROCK HL600 (D=45mm)	525
T38	TAMROCK HL600 (D=45mm)	600
T45	TAMROCK HL600 (D=45mm)	600
T45	TAMROCK HL600 (D=52mm)	650
T51	TAMROCK HL600 (D=52mm)	650
T38	TAMROCK HL700/HL710/HL800T/HF810T/HL650 (D=45mm)	600
T45	TAMROCK HL700/HL710/HL800T/HF810T/HL650 (D=45mm)	600
T51	TAMROCK HL700/HL710/HL800T/HF810T/HL650 (D=45mm)	600
T38	TAMROCK HL700,HL710,HL800,HF810,HL650,HL810 (D=52mm)	600
T45	TAMROCK HL700,HL710,HL800,HF810,HL650,HL810 (D=52mm)	600
T51	TAMROCK HL700,HL710,HL800,HF810,HL650,HL810 (D=52mm)	600
T45	TAMROCK HL1000, HL1010, HL1010S (D=52mm)	590
T51	TAMROCK HL1000, HL1010, HL1010S (D=52mm)	590
T45	TAMROCK HL1000, HL1010, HL1010S (D=52mm)	670
T51	TAMROCK HL1000, HL1010, HL1010S (D=52mm)	670
T51	TAMROCK HL1000, HL1010 (D=60mm)	670
T60	TAMROCK HL1000, HL1010 (D=60mm)	670
MT60	TAMROCK HL1000, HL1010 (D=60mm)	670
T58	TAMROCK HL1000 (80mm), HL1010, (SHOULDER DRIVE)	635
T68	TAMROCK HL1000 (80mm), HL1010, (SHOULDER DRIVE)	635
T51	TAMROCK HL1000 EXTRACTOR (D=52mm)	840
T51	TAMROCK HL1500 (D=60mm)	760
T60	TAMROCK HL1500 (D=60mm)	760
MT60	TAMROCK HL1500 (D=60mm)	760
T58	TAMROCK HL1500 (D=80mm) (SHOULDER DRIVE)	635
T68	TAMROCK HL1500 (D=80mm) (SHOULDER DRIVE)	635
T51	TAMROCK HL1500PE,1000PE,1560T(D=65mm)	760
T60	TAMROCK HL1500PE,1000PE,1560T(D=65mm)	760
MT60	TAMROCK HL1500PE,1000PE,1560T(D=65mm)	760

Contact Details
info@pmt-uae.com
www.pmt-uae.com
00971501217751,00971501210275