



PIONEERS

For Mining Trading E.Z.C

Drilling solutions for Construction, Mining & Quarrying Industry







Pioneers for Mining Trading established in 2015 is one of the largest manufacturers of Diamond Core Bits, Core!Drilling Accessories and exploration tools in India. We specialize in producing high-quality diamond!core drilling tools which are used for mining, mineral exploration, geotechnical drilling exploration and diamond core drilling

Pioneers for Mining Trading diamond tools of British Standard, Swedish Standard and Wireline !standards strictly as per their specifications. Our products include diamond core drilling accessories, Diamond core bits- Impregnated and Surface set, Reamer shell -impregnated and Surface set, Non-Coring bits, Casing shoe and Casing Bits, Drill Rods, Core Barrels, Casings, Core lifters, core lifter case,!Water Swivel, Hoisting Plugs, Heads, Subs, Recover Taps used in geotechnical drilling and exploration

We have owned an excellent specialized team of experts and the most advance manufacturing!technology and equipment. Besides standard products, we also provide customized products “according to customers’ requirements. We believe in giving our clients “Value for Money

!We at Pioneers For Mining Trading at excellence, do our best to improve customer service. We have the .advantage of providing premium quality products and the most timely services

"WE EQUIP FOR THOSE WHO EXPLORE THE EARTH'S TREASURE"

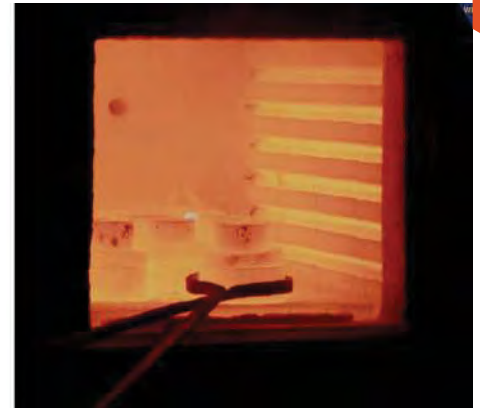

HOW WE DO IT

01. SOURCING

We have a good relationship with all our suppliers. Our well-established network with quality suppliers has enabled us to provide quality products to our clients.

02. TECHNOLOGY

We have a manufacturing unit set-up in an area of 30,000 square feet, well equipped with the most advanced machinery and equipment to manufacture our products.

03. DEVELOPMENT

Having more than 30 years of experience has given us the expertise of making optimum utilization of the resources and providing our client a quality product at a competitive price.

04. TESTING

To ensure that the best quality products are delivered to our client, all our products go through a quality checking and testing process before it is delivered to our client.

05. DELIVERY

The packaging of our product is taken care of by our packaging department to ensure all our products are properly labelled and packed before it is dispatched. We have various logistic partners helping us to provide on-time delivery of goods.

06. ASSISTANCE

Our clients are most valuable to us therefore we provide customer service and after sale assistance to them in order to ensure customer satisfaction.

CORE BIT

STANDARD SPECIFICATION

DCDMA/BSS STANDARD

AX, BX, NX, HX, PX, SX, AXM, BXM, NXM, AWG, BWG, NWG, HWG, PWG, SWG, AWF, BWF, NWF, HWF, PWF, SWF, UWF, ZWF, AWT, BWT, NWT, HWT, NMLC, HMLC

SWEDISH STANDARD

T2 - 36mm, 46mm, 56mm, 66mm, 76mm, 86mm, 101mm
T6 - 66mm, 76mm, 86mm, 101mm, 116mm, 131mm, 146mm

WIRELINE STANDARD

AQ, BQ, NQ, HQ, PQ, NQ3, HQ3



Impregnated Diamond Core Bits are made using very small, high-quality synthetic diamond grits mixed evenly through a metal matrix and are reinforced with carbide and diamond. It is used for cutting medium to ultra-hard formations. The impregnated diamond bit is used for grounds ranging from broken and highly abrasive to fine-grained, consolidated and ultra-hard rock. The bit re-sharpens, exposing new diamonds as it drills, renewing the cutting edges.

Surface Set Diamond Core Bit is made for coring soft to medium-hard formations. They are set with natural diamonds in a tungsten carbide matrix with diamond and carbide reinforcements. They are generally recommended for relatively soft, unconsolidated formations and harder formations where the RPM's and bit loads required for impregnated bits are not available.

Surface Set Diamond core bits are available in 15/20spc, 20/30spc, 30/40spc, 40/60spc, 60/80spc & 80/110spc. (SPC=stones per carat). Other diamond sizes are available upon request.



Tungsten Carbide Core Bit is designed to cut soft formations with very small gravel, sticky shales or clay. Tungsten carbide inserts are selectively placed in the carbide matrix. Waterways are designed for the optimum discharge of fluid and aid in controlling matrix abrasion to maximize cutting efficiency and penetration.

IMPREGNATED DIAMOND CORE BIT

MATRIX HARDNESS & BIT PROFILE

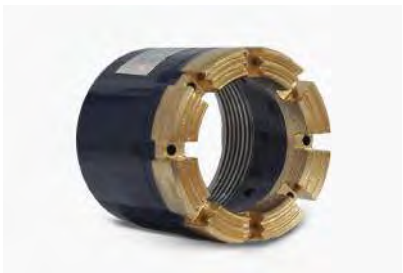

ROCK CHARACTERISTIC	SOIL TYPE	MOHS HARDNESS SCALE	WESBEN'S (SERIES)
Extremely Hard, Unbroken Fine Grained Formation, Non-abrasive	Quartz, Chert Jasper	8-9	SERIES 14
Very Hard, Unbroken Fine Grained Formation, Non-abrasive	Quartzite, Taconites Diorites	8	SERIES 10
Hard, Fine to Medium Grained Unbroken Formation	Granite, Andesite, Gneiss Schist	7	
Moderately Abrasive, Medium to Coarse Grained Formations Solid to Slightly Fractured.	Pegmatite, Monzonite Gabro	6	SERIES 9
Abrasive, Medium to Coarse Grained Formations, Broken	Quartzite, Conglomerate Sandstone, Rhyolite	5	
Abrasive, Medium to Coarse Grained Formations, Broken	Sandstones, Pegmatite Taconites, Quartzite	4-5	SERIES 8
Extremely Abrasive, Medium to Coarse Grained Highly Fractured, Gaulty and Sheared Ground	Sandstones, Quartzite Limestone	4	

BIT PROFILE



FLAT PROFILE

It's suitable for various rocks, often used impregnated casing bits, casing shoes as well as the bits with very hard matrices.



SEMI ROUND PROFILE

Even diamond distribution in the bit face, suitable for drilling medium-hard and hard rocks, or a little broken and loose formation.



SERRATED/W PROFILE

Standard profile for most impregnated bits. It provides good drilling stability and is suitable for various formations.



MULTI-STEP PROFILE

Multi-Step type impregnated bit are suitable for soft to medium hard formations and alternating hard-soft formations.

CROWN HEIGHT

We offer a crown height of 10mm, 12mm & 13mm. It can also be made as per our client's requirement.

Taller the crown height, better is the stability and life of the bit.

WATERWAY CONFIGURATIONS



.5



STANDARD/ CHANNEL FLUSHING

Standard waterways are recommended for most general-purpose coring operations and offer great fluid circulation in a variety of conditions.



FACE DISCHARGE

Recommended for very soft and broken formations or when using triple -tube(WL3) barrels Face Discharge waterways increase flushing characteristics to prevent waterway blockage by ejecting fluid through ports molded into the face of the bit.



TURBO

Turbo Bits waterways provide increased flushing ability and lessen the contact area of the bit to the rock, therefore giving the bit more cutting ability with less pressure.



DEEP I.D. WATERWAYS



Designed to maximize the waterway depth on the I.D. of the bit, which reduces the jetting or washing away of the core. The extra clearance minimizes the vacuum effect caused by the water flow past the lifter case in a lost circulation application.

SURFACE SET DIAMOND CORE BIT

SIZE GUIDE



.6

	MULTI-STEP	DIAMOND SIZE	FORMATION
	SEMI-ROUND	10/20 SPC	Soft Formation
	FACE DISCHARGE	20/30 SPC	Soft to Medium Formation
		40/60 SPC	Medium to Hard Formation
		<60/80 SPC	Very Hard Formation

TUNGSTEN CARBIDE CORE BIT



The Tungsten Carbide core bit is designed to cut soft formations with very small gravel, sticky shales or clay. Tungsten carbide inserts are selectively placed in the carbide matrix.

Advantages:

- Compare to diamond core bit. these are relatively cheaper.
- Cut effectively at low r.p.m. and low weight on bit.
- In soft formations, they can be cost-effective.

DIAMOND REAMER SHELL

FRONT & BACK REAMER



Diamond Reaming Shell is connected to a core bit. While the drilling is done by the bit, grinding of the side surface can be done simultaneously. The outside surface of the reamer shell is inset with diamonds to maintain the gage of the hole as the O.D. of the core bit wears. Diamond reamer shell is used to prevent early wear and tear of the outer diameter of the Bit and is also used to prevent vibration and deformation of the hole walls. Having a cylindrical shape, with diamond particles attached at the outside diameter. The diameter of the reaming shell is made bigger than that of a bit.



FEATURES

Pioneers for Mining Trading Reaming Shell comes in two varieties: one for general rocks and the other is the screw type for stronger rocks. Wesben's Reaming Shell has a long life span and outstanding reaming ability because it is made with a high-quality shank and diamond

CASING SHOE & BIT

IMPREGNATED, SURFACE SET & TC.



Impregnated Diamond Casing Bit and Casing Shoe bits are made with diamond grits. These diamond grits are inserted into a powdered metal bond into the core and matrix of the bit.

Surface Set Diamond Casing Bit and Casing Shoe are made for hole opening. Surface set diamond casing and casing shoe bits are made with natural diamonds placed on the bit crowns.

Tungsten Carbide Casing Bit and Casing Shoe have an advantage over the price, economical application, which is suitable for medium hardness rocks.

Rod Shoe is designed to offer better performance and longevity in a variety of drilling operations. We offer Rod Shoe in standard sizes.



DRILL ROD

SIZE GUIDE

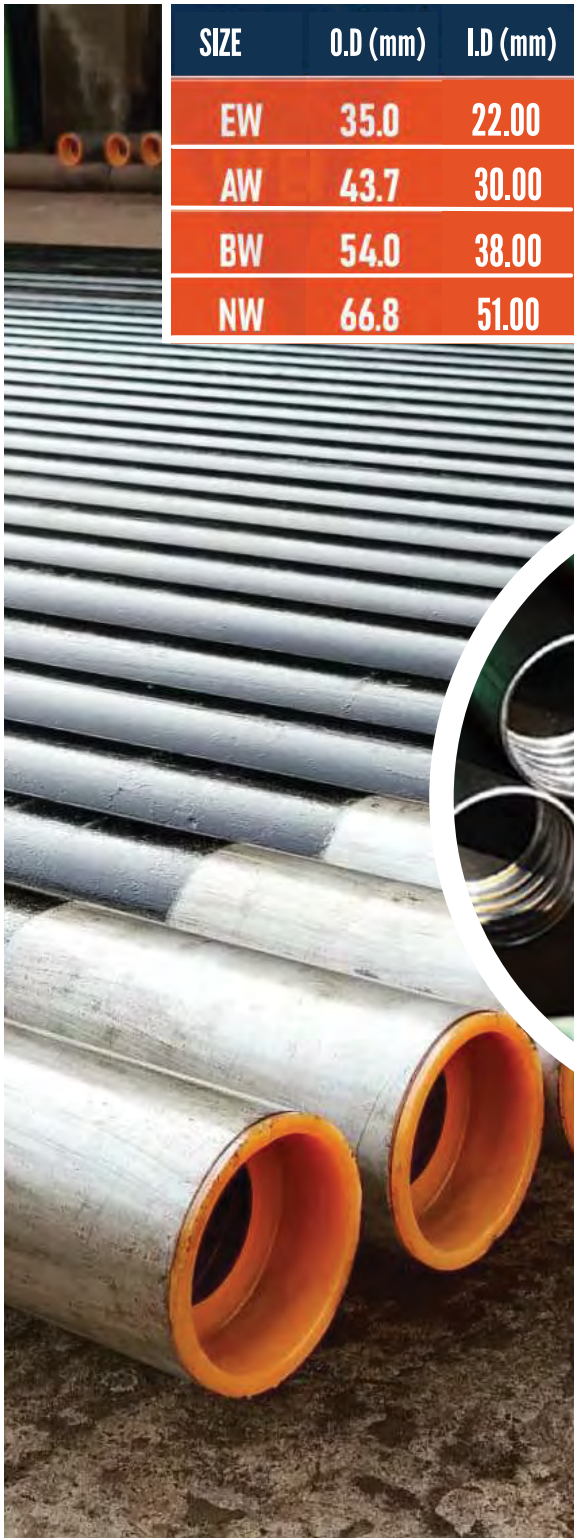

SIZE	O.D (mm)	I.D (mm)
EW	35.0	22.00
AW	43.7	30.00
BW	54.0	38.00
NW	66.8	51.00

SIZE	O.D (mm)	I.D (mm)	Thread Length	Pipe Length (mm)	Threads Pitch	Weight kgs
BQWL	55.6	46	44.45	1500	8.5mm	9.00
				3000		18.00
NQWL	69.9	60.3	44.45	1500	8.5mm	12.00
				3000		24.00
HQWL	88.9	77.8	44.45	1500	8.5mm	17.00
				3000		34.00
PQWL	114.3	103.2	63.5	1500	10.2mm	25.5
				3000		51.00



Our Drill Rods are made using strong and ductile alloy steel pipe which is thermal processed and heat treated. The threading is done using a CNC machine and is hardened to achieve world standard accuracy. We ensure that the material composition and specifications are as per the client's requirement.

CASING TUBE

SIZE GUIDE

SIZES

RW/RX, EW/EX, AW/AX, BW/BX, NW/NX, HW/HX, PW/PX, SW/SX,
UW/UX, ZW/ZX

46mm, 56mm, 66mm, 76mm, 86mm, 101mm, 116mm,
131mm, 146mm



Casing Pipes are required in order to maintain the hole wall to the depth desired during the drilling operation. Used in poor ground conditions, casing pipes are used to safeguard the internal space of the hole.

"W" & "X" SERIES

"W" series casing tubes are flush jointed (without a coupling) internally and externally, with an integral pin and box thread.

"X" series casing tubes are flush coupled. They have a box thread at both ends and include a pin to pin casing coupling.

Casing couplings may be replaced when threads are worn or damaged and can be supplied separately.

METRIC SERIES

They are flush jointed as well as flush coupled. Metric casing tubes are thin-walled, providing light-economical drill string and offer a wider range of dimensions than the DCDMA-BS casing tubes. This means less reduction of the hole diameter when the hole is cased.

The standard effective lengths are 3.0 & 1.5 meters. Other lengths may be manufactured upon request. All casing tubes have right-hand threads. Left-hand threads can be manufactured if requested. Our Metric and DCDMA-BS casing tubes, "W" & "X" series, are manufactured from the best quality cold drawn seamless steel tubes with the high tensile strength to withstand heavy stresses. Straightness is more than 1:1800. They are in accordance with ISO 3551-1.1992

TECHNICAL SPECIFICATIONS

DRILL ROD & CASINGS

RAW MATERIAL

SAE - 1541/1040
Grade Steel
We select the best
steel tubes available in
the market to
manufacture Drill
Rods and Casing
Pipes.

TREATMENT

All our Wireline Rods are
hard-chromed/induction
hardened to increase it's
service time.

THREADING

We use CNC latches & form cutter in
thread opening process to minimize
errors. The thread surface are then
phosphated to increase the surface
conditions



OTHER SPECIFICATIONS

- Min. Tensile Strength: 900 N/mm²
- Min. Yield Stress : 800 N/mm²
- Min. Extension : 14%
- Min. Surface Hardness : HRC 30 ~ 35
- Seamless, Cold drawing
- Roundness : 0.2 Max Standard
- Straightness : 0.8/1000mm (Standard)

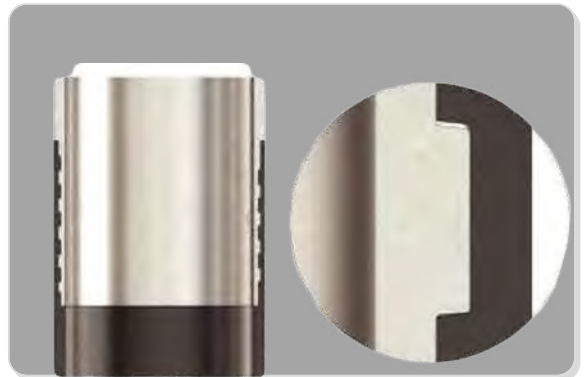



CORE BARREL

DCDMA/BSS & METRIC STANDARD

DCDMA/BSS STANDARD	AX, BX, NX, HX, PX, SX, AXM, BXM, NXM, AWG, BWG, NWG, HWG, AWF, BWF, NWF, HWF, PWF, SWF, UWF, ZWF, AWT, BWT, NWT, HWT, NMLC, HMLC
SWEDISH STANDARD	T2 - 36mm, 46mm, 56mm, 66mm, 76mm, 86mm, 101mm T6 - 66mm, 76mm, 86mm, 101mm, 116mm, 131mm, 146mm
WIRELINE STANDARD	BQWL, NQWL, HQWL, PQWL, NQWL3, HQWL3

Single Tube Core Barrel is a tubular component made of cold drawn seamless tube. Water is continuously in contact with the core, causing it to erode.

Single tube core barrels have the lowest core recovery and are typically utilised for core drilling in continuous hard rock formations or non-core drilling where core recovery is not critical. Hard metal strips at the head, hard chrome plated on both ends of the tube with core lifter, blank reaming shell, and blank bit are standard on all single tube core barrels.

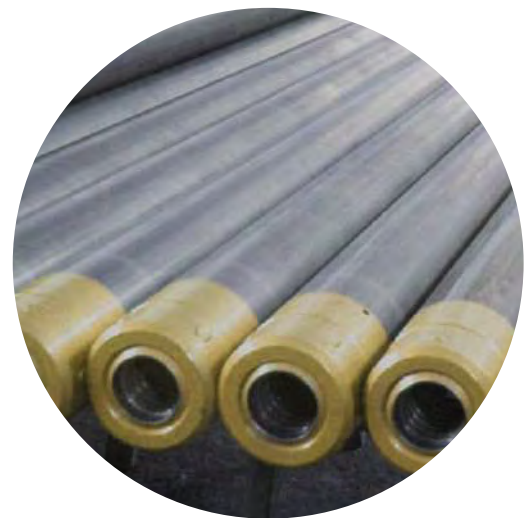

Double Tube Core Barrel has a swivel head, which means the inner tube is connected to the core barrel head through bearings, allowing the inner tube to rotate independently of the core barrel.

Water flows between the outer and inner tubes of the twin-tube core barrel. Water can flow via perforations on the inner tube's lower end. The diamond core bit is the sole spot where the core is susceptible to erosion from this point on.

Triple Tube Core Barrel is used for dam and bridge research, geotechnical study, diamond core drilling, soil investigation, foundation testing of high-rise buildings, and mineral discovery with approximately 100% core recovery. With the assistance of a piston mechanism, air or water is forced into the head, and the third tube/split tube emerges. After that, the upper half of the split tube is raised, revealing the core in its original state.

Wireline Core Barrels have become the industry standard for high-volume core recovery. Wireline core barrels from Wesben are built of high-quality materials and are available in all typical industrial designs. They are also fully compatible with other readily accessible suitable spare components for added convenience.



All spare parts and conversion kits can be supplied as a kit or separate to reduce the cost of the coring system.

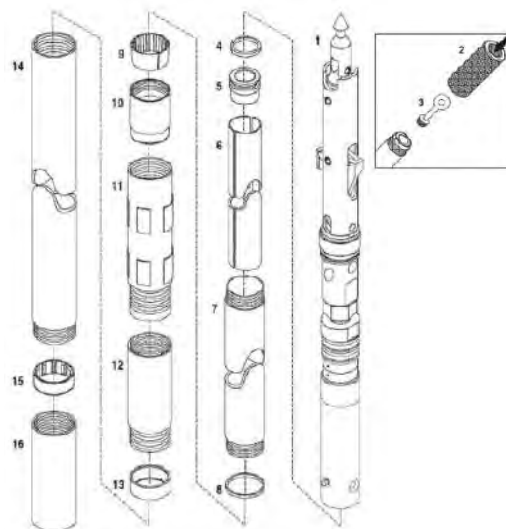

W/L3 CORE BARREL ASSEMBLY

1. Head Assembly
2. Pump-out Adaptor
3. Piston Plug
4. O Ring
5. Core Ejection Piston
6. Split Inner Tube 1.5m or 3.0m
7. Inner Tube 1.5m or 3.0m
8. Stop Ring
9. Core Lifter
10. Core Lifter Case
11. Locking Coupling
12. Adaptor Coupling
13. Landing Ring
14. Outer Tube 1.5m or 3.0m
15. Inner Tube Stabilizer
16. Thread Protector

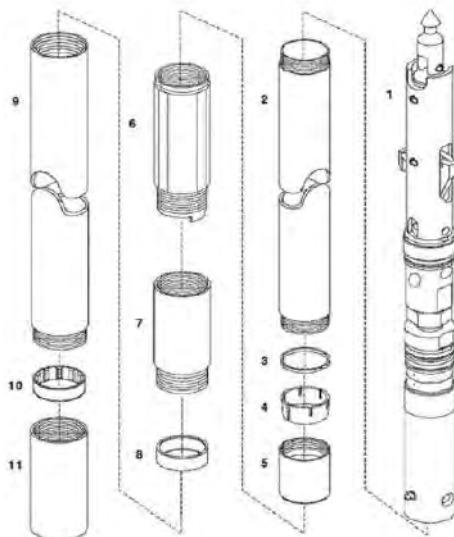

W/L CORE BARREL ASSEMBLY

1. Core Barrel Head Assembly
2. Inner Tube 1.5m or 3.0m
3. Stop Ring
4. Core Lifter
5. Core Lifter Case
6. Locking Coupling
7. Adapter Coupling
8. Landing Ring
9. Outer Tube 1.5m or 3.0m
10. Inner Tube Stabilizer
11. Thread Protector

CORE CASE ASSEMBLY

CORE CASE & LIFER, RING & STABILIZER

A core lifter or core catcher is used to hold the core inside the barrel. Our core lifters are made from high-quality steel which is perfectly hardened ensuring better performance and longer life. Both broached core lifters and slotted core lifters are manufactured.



Core Lifter Case is needed to break the core sample. Having a tapered interior helps the core lifter from not moving and enables it to retain its hold on the core sample.

The Stop Ring ensures that the core lifter stays in the core lifter case. It is easily inserted into the grooved space provided in the core lifter case.

the inner tube Stabilizers are made of high-quality bronze alloy. The purpose of the inner tube stabilizer is to stabilize the inner tube at the bottom of the hole, directly above the bit or near the core lifter case.



OTHER ACCESSORIES

ADDITIONS

WATER SWIVEL



HOISTING PLUG



SPT TUBE



ADAPTERS



RECOVERY TAP



JAR HAMMER





PIONEERS
For Mining Trading F.Z.C

GET IN TOUCH

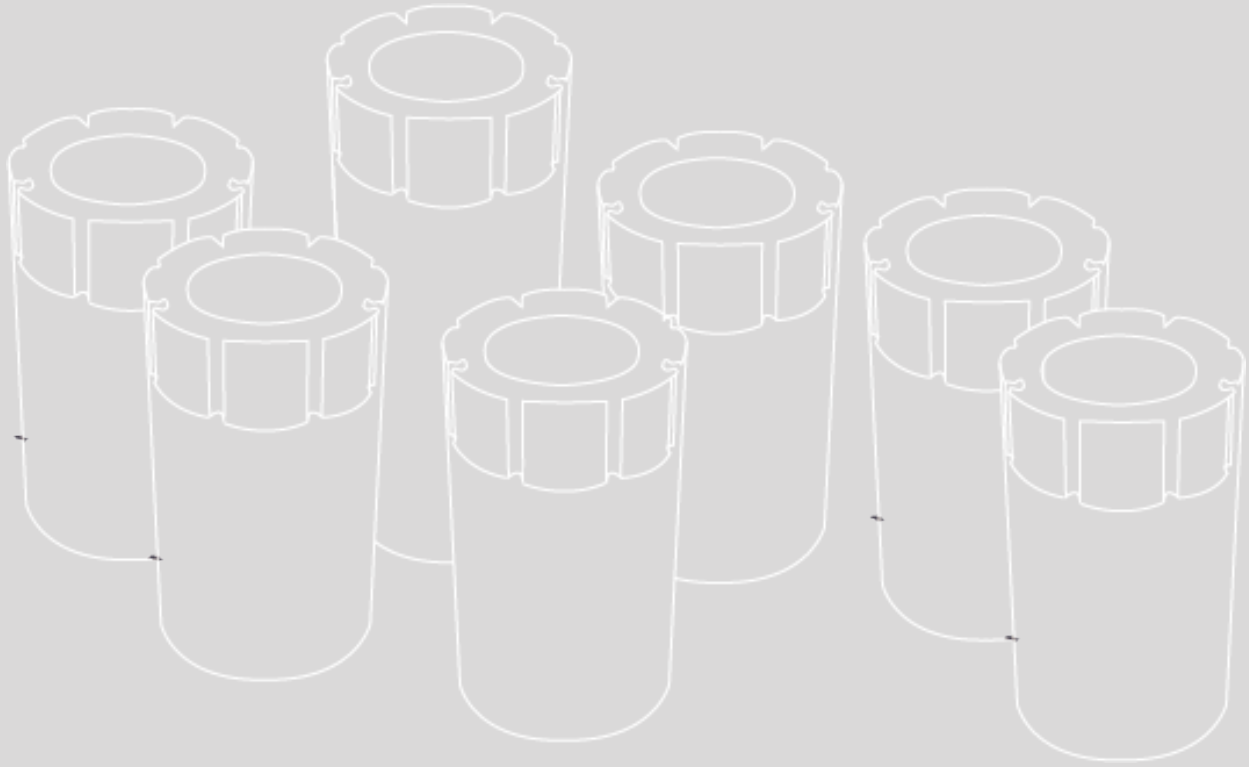

Waerhouse A1-13 Gate No. 1
Ajman Freezone, UAE



00971501217751



00971501217751



info@pmt-uae.com